

P/N 7711037

CLINISPIN □ 755 VES horizon



Operator's Manual

Rev. 1.0

CLINISPIN HORIZON 755VES Laboratory Centrifuge

Table of Contents

Model Description	page 3
Supplied Equipment	page 3
Warranty Information.....	page 3
Specifications	page 4
Control Panel / Parts of the Centrifuge.....	page 5
Setup Location	page 6
Initial Setup Procedure	pages 6,7
Operation	page 7
Rotor Configurations	
Horizontal Rotor	page 8
6-Place 50mL Fixed-Angle Rotor.....	page 8
20-Place Fixed Angle Rotor	page 9
Control Panel Functions	
Time Adjustment and Timer Operation	page 10
Speed Adjustment / RCF Display	page 10
Starting and Stopping a Run	page 10
Unlocking the Lid	page 10
Advanced User Settings	
Acceleration Rate	page 10
Braking Rate	page 11
Countdown Delay	page 11
Imbalance Detection	page 11
Audible Setting	page 11
Memory Locations / Storing and Recalling	page 12
Mechanical Cycle Counter	page 12
Care and Preventative Maintenance	page 13
Troubleshooting	page 14
Safety	page 15
Emergency Rotor Chamber Entry	page 15
Calibration and Earth Ground Testing	page 15
Replacement Parts	page 16

WARNING: For the safety of both the operator and service personnel, care should be taken when handling substances that are known to be toxic, radioactive or contaminated with pathogenic microorganisms when using this centrifuge. When Risk Group II materials are used (as identified in the World Health Organization "Laboratory Bio-Safety Manual"), a Bio-Seal should be employed. More than one level of protection must be provided in the case of materials of a higher group. The use of flammable or explosive materials as well as those materials which chemically react vigorously is prohibited.

SUPPLIED ACCESSORIES (Standard)

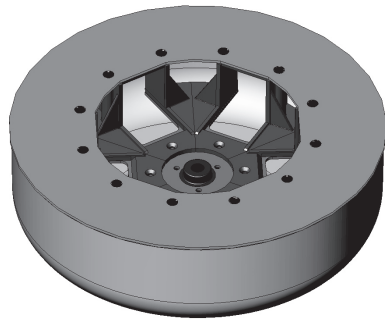

One (1) 6-Carrier
Horizontal Rotor*

Six (6)
60mL Carriers*

Also included (not shown):

- One (1) Mains Lead
- One (1) Operator's Manual

Available Accessories:

- 6-Place Carrier, for tubes up to 17mm x 125mm
- 30-50mL Carrier



WARRANTY:

Woodley Equipment Company warranties that this centrifuge is free from defects in workmanship and parts for 12 months.

WOODLEY
EQUIPMENT COMPANY LTD

Made in the USA

Old Station Park Buildings
St. John's Street, Horwich
Bolton BL6 7NY, United Kingdom
Tel: +44 (0) 1204 669033 • Fax: +44 (0) 1204 669034
www.woodleyequipment.com Email: sales@woodleyequipment.com
www.horizoncentrifuges.com Email: sales@horizoncentrifuges.com

•The rotor and rotor accessories are rated for a rotational speed of 3500 RPM (a force of 2200 xg).

CLINISPIN 755 VES horizon

SPECIFICATIONS:

Specifications for the Clinispin Horizon 755VES Centrifuge

Maximum Speed:	3500 RPM
Maximum Force (RCF):	2200 xg
Overall Dimensions (H x W x D):	23 x 37 x 43 cms
Centrifuge Motor:	1/2 H.P. Brushless DC
Protection Breaker:	4 Amp. re-settable
Timer:	electronic, with hold or 0 to 99 minutes, +/- 1%
Weight:	17.7 kgs

Permitted Environmental Conditions

Ambient Temperature During Operation: 2 °C - 35 °C

Maximum Relative Air Humidity: 90%

Electrical Requirements:

Power: 200 Watts

Voltage: *North America:* 115 Volts (+/- 10%)

Japan: 100 Volts (+/- 10%)

Europe: 230 Volts (+/- 10%)

50/60 Hz

Frequency:

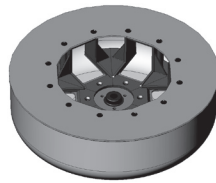

	PART NO. #	MAX TUBE SIZE	SPEED RANGE	FORCE RANGE
6-Carrier Horizontal (Standard)	7786022	Comes with your choice of 6 of the holders listed		
w/4-Place Carrier	7713023	24 17mm x 100mm	500 to 3,500 RPM	40 to 2,200 xg
w/4-Place Carrier	7713023	12 17mm x 125mm	500 to 3,500 RPM	40 to 2,200 xg
w/50mL Hor. Carrier	7713037	6 34mm x 115mm	500 to 3,500 RPM	40 to 2,200 xg



6-Place 50mL Fixed-Angle	7786044	Comes with 6 of the holders listed		
w/50mL Fixed-angle holder	7787051	6 34mm x 125mm	500 to 4,000 RPM	40 to 2,000 xg



20-Place Fixed-Angle	7786042	Comes with 20 of each of the holders listed		
w/75mm tube holder	7713043	20 17mm x 75mm	500 to 4,000 RPM	40 to 1,700 xg
w/100mm tube holder	7713040	20 17mm x 100mm	500 to 4,000 RPM	40 to 1,900 xg
w/125mm tube holder	7713044	20 17mm x 125mm	500 to 4,000 RPM	40 to 2,000 xg

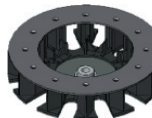

12-Place Horizontal	7786024	Comes with 20 of each of the holders listed		
w/75mm tube holder	7713043	20 17mm x 75mm	500 to 3,200 RPM	40 to 1,240 xg
w/100mm tube holder	7713040	20 17mm x 100mm	500 to 3,200 RPM	40 to 1,540 xg
w/125mm tube holder	7713044	20 17mm x 125mm	500 to 3,200 RPM	40 to 1,830 xg



Any use other than those specified by the Manufacturer is explicitly prohibited. Maximum sample density is 1.15 grams / mL, (water density = 1.0 grams / mL) *See label on rear of centrifuge for voltage requirements.

CONTROL PANEL / PARTS OF THE CENTRIFUGE:

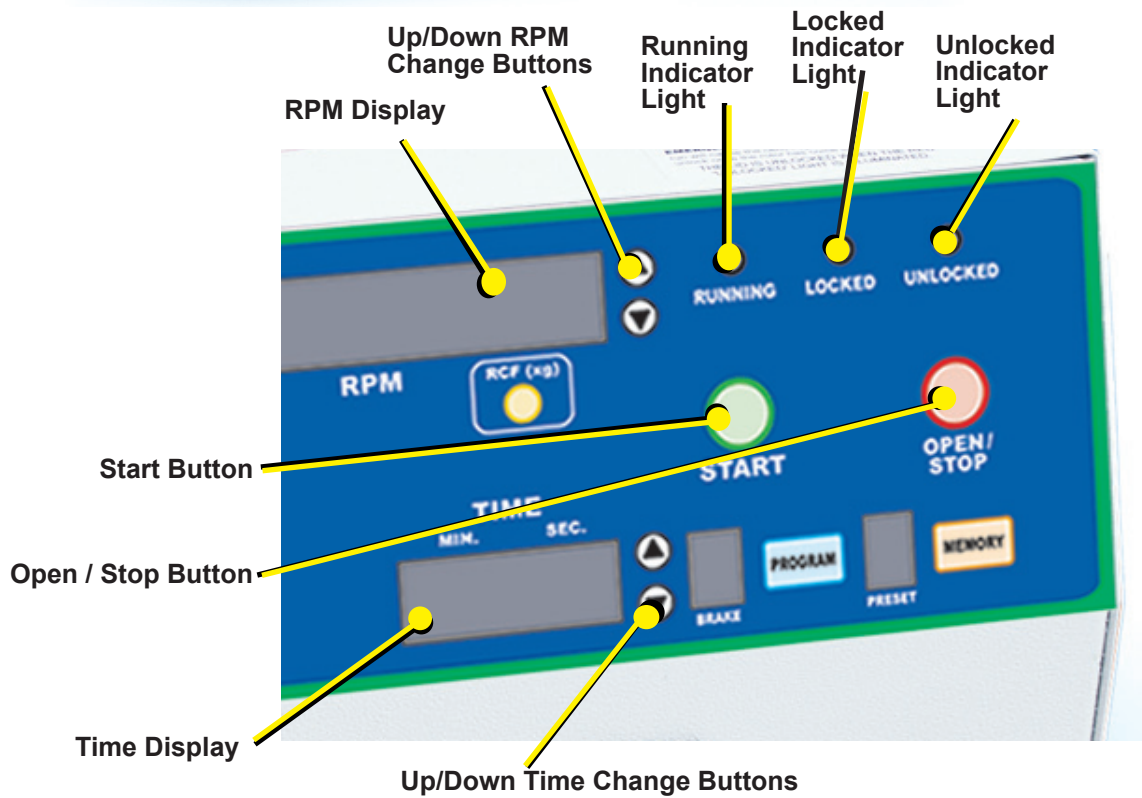

SETUP LOCATION:

1. Unpack the centrifuge and verify that all of the supplied equipment is present.
2. Choose a setup location which meets the following criteria:
 - a) A bench top clearance height of 51 cms” is required in order to open the lid.
 - b) The clearance envelope is the space around the centrifuge which is required for safety. Choose a setup location which will allow for a clearance envelope of at least 76 x 76 cms, (with the centrifuge at the center). No person or hazardous material shall be permitted in the clearance envelope during operation. The operator time within the envelope shall be limited to the time necessary for loading, unloading and centrifuge operation only.
 - c) Proper ventilation is necessary to prevent the overheating of samples as well as premature failure of the centrifuge. Choose an area which will allow unencumbered air flow.
 - d) The centrifuge is designed to rest on its four rubber feet. No adjustment is necessary for leveling the centrifuge, however, the surface should be flat and level.
 - e) **Be sure the outlet is always within reach as the mains lead is the means of emergency disconnection!**

INITIAL SETUP PROCEDURE: *If any problems are found during the initial setup procedure, refer to the troubleshooting section. For further assistance, contact Woodley Equipment Company. +44 (0) 1204 669033.*

1. Plug the female end of the mains lead into the rear of the centrifuge. Plug the male end into an approved electrical outlet. For electrical safety, the unit must always be properly grounded.
2. Engage the power button on the front of the centrifuge (if it is not already engaged). The power button is engaged when it is illuminated.
3. For operator safety, the locking system is always active; requiring power and direction from the user to disengage it (the lid also automatically unlocks at the end of a run when it is safe to do so). To unlock the lid (in order to access the rotor chamber) press the 'OPEN / STOP' button on the control panel. The 'UNLOCKED' indicator light should illuminate. If it does not, refer to the section on troubleshooting. The lid will remain unlocked for 15 seconds after pressing the 'OPEN / STOP' button.
4. Turn the Lock counterclockwise and open the lid.
5. Spin the rotor by hand; check for free and level rotation. If the rotor does not spin freely, refer to the section on troubleshooting.
6. Place the test tube carriers into the rotor and verify that they are seated properly.
7. Close the lid. Rotate the lid knob clockwise to its complete stop position. The 'LOCKED' indicator light should be illuminated. If it is not, make sure that the lid is latched properly. The centrifuge will not run unless the lid is latched properly and the 'LOCKED' indicator light is illuminated.
8. Initiate a test run by pressing the 'START' button.
9. The 'RUNNING' indicator light will illuminate and the cycle counter will increment by one.
10. The test tube carriers will slide up into the horizontal position and the unit will accelerate to the current set speed.
11. Listen to the sound of the centrifuge. A smooth whirring sound should be heard. If there are any loud or unusual sounds, stop the centrifuge by pressing the 'OPEN / STOP' button immediately and refer to the section on troubleshooting.

(continued on next page)

INITIAL SETUP PROCEDURE (continued):

12. Press the 'OPEN / STOP' button to terminate the test run. The rotor will decelerate to a complete stop and the lid will then unlock automatically for sixty (60) seconds.
13. The centrifuge is now ready for operation.

OPERATION:

NOTE: Follow the initial setup procedure before initial operation.

1. Press the 'OPEN / STOP' button to unlock the lid and then open the lid.
2. Place the test tube samples into the tube carriers. Be sure to follow the rules for balanced loads.
3. Close the lid and turn the lid knob clockwise to its complete stop position. The 'LOCKED' indicator light should illuminate to indicate that the latch is closed properly. If the lid knob is not completely latched, the 'LOCKED' indicator light will not illuminate and the centrifuge cannot be operated.
4. Set the desired speed and run time using the appropriate up and down arrow buttons.
5. Begin the run by pressing the 'START' button on the control panel.
6. The centrifuge should begin to spin. The 'RUNNING' indicator light should illuminate.

IF A PROBLEM IS FOUND DURING A SPIN THAT REQUIRES THE CENTRIFUGE TO SHUT DOWN, PRESS THE 'OPEN / STOP' BUTTON IMMEDIATELY !

7. After time has elapsed, the 'RUNNING' indicator light will extinguish and the rotor will decelerate to a complete stop.
8. The 'UNLOCKED' indicator light will illuminate and the locking mechanism will disengage, allowing entry into the rotor chamber. If the automatic unlock times out after 60 seconds) simply press the 'OPEN / STOP' button.
9. Turn the lid knob counterclockwise and open the lid.
10. Remove the samples.
11. The centrifuge may be used immediately.

ROTOR CONFIGURATIONS:

This rotor is designed to hold up to 6 tube carriers.
Follow the procedure below for proper tube loading.

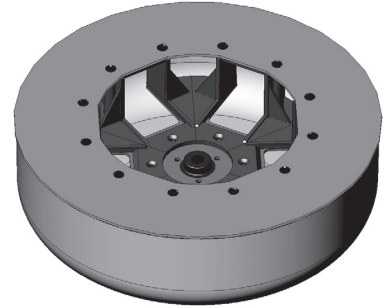

Six (6) Carrier Horizontal Rotor (standard):

Your centrifuge must contain a balanced load in order to work properly. To ensure that the load is balanced, keep these rules in mind when inserting test tube samples into the four (6) position horizontal rotor:

1. *Opposing tube carriers must be identical.*
2. *Opposing tube carriers must be empty or loaded with an equal number of equally weighted samples.*
3. *If an odd number of samples is to be spun, use a water-filled tube to mate with the unpaired one.*

1. *Opposing tube carriers must be identical.*
2. *Opposing tube carriers must be empty or loaded with an equal number of equally weighted samples.*
3. *If an odd number of samples is to be spun, use a water-filled tube to mate with the unpaired one.*

4. *(Four Position Carriers Only):
When loading tubes into opposing carriers, the carriers will be balanced when the tubes are loaded diagonally from one another (not across from one another).
For example: six tubes are to be loaded into two carriers. In each carrier, two tubes are placed in the bottom and one tube is placed in the upper left-hand position. See picture at right.*

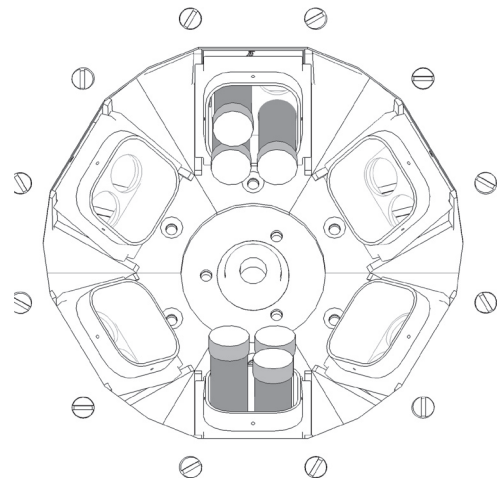

NOTE: Do not load more than two (2) tubes per carrier if the tubes are greater than 100mm long (15mL). When loading these tubes into the carriers, place them all on either side. For example, to load twelve (12) 15mL tubes, place two tubes on the right-hand side of each carrier.

WARNING: When using glass test tubes, place a 7mm cushion at the bottom of each location in the carriers. Failure to do so may result in damage to the test tube.

Six (6) Place 50mL Fixed-angle Rotor (optional):

This rotor is designed to hold up to six (6) 50mL tube holders.

Your centrifuge must contain a balanced load in order to work properly. To ensure that the load is balanced, keep these rules in mind when inserting test tube samples into the 6 place, 50mL fixed-angle rotor:

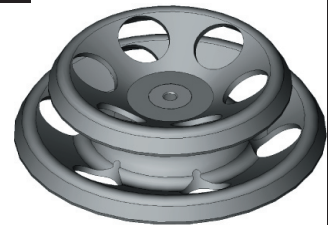

1. *Opposing tube holders must be identical.*
2. *Opposing tube holders must be empty or loaded equally weighted samples.*
3. *If an odd number of samples is to be spun, use a water-filled tube to mate with the unpaired one.*

Twenty (20) Place Fixed-angle Rotor (optional):

This rotor is designed to hold up to twenty (20) tube holders. It comes with three tube holder types. The orange holders are designed to hold tubes up to 15mL (up to 17mm x 125mm). The purple holders are designed to hold tubes up to 10mL (up to 17mm x 100mm). The blue holders are designed to hold tubes up to 5mL (up to 17mm x 75mm).



Your centrifuge must contain a balanced load in order to work properly. To ensure that the load is balanced, keep these rules in mind when inserting test tube samples into the 20 place fixed-angle rotor:

1. Opposing tube holders must be identical.
2. Opposing tube holders must be empty or loaded equally weighted samples.
3. If an odd number of samples is to be spun, use a water-filled tube to mate with the unpaired one.

DIRECTIONS:

1. Compare the tube to be spun with the four boxes shown below.
2. Find the box that most closely matches the tube's length. NOTE: The tube length with its stopper or cap must be shorter than the chosen box.
3. Match the letter from the chosen box with one of the configurations shown.

A. For Example: A tube is found to be as long as box B. Accordingly, we can use a 125 mm tube holder with a 1525 cushion, (configurations B1 or B2).

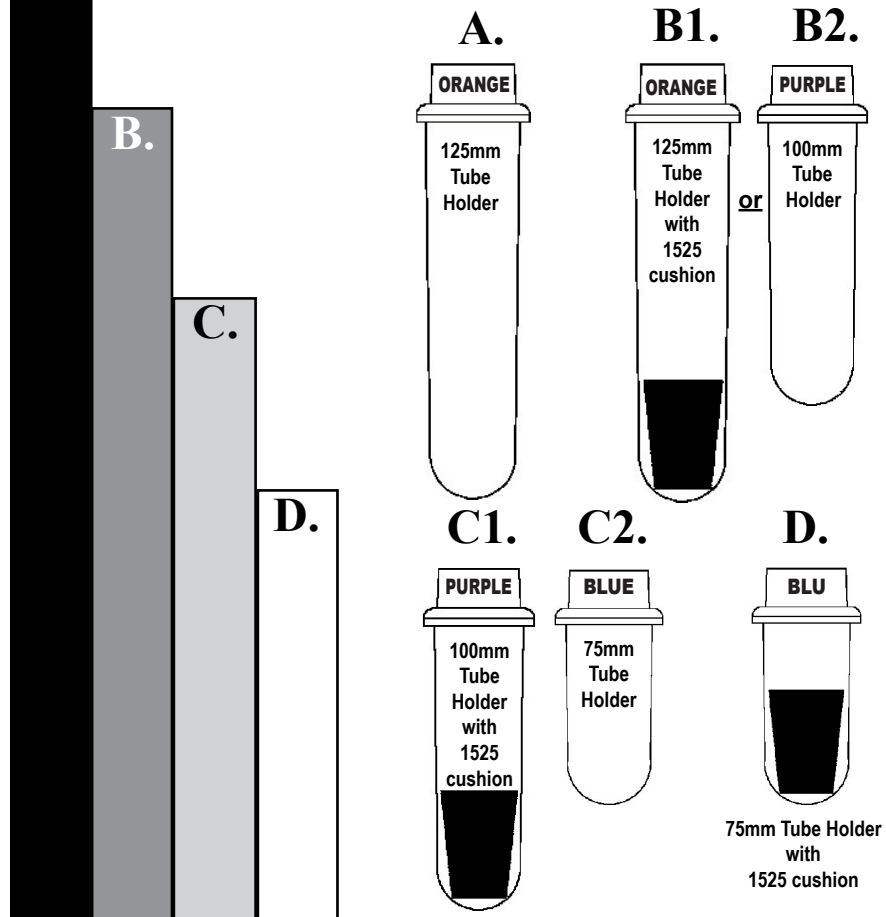

CONTROL PANEL FUNCTIONS:

Time Adjustment and Timer Operation

The run time may be set from 30 seconds to 99 minutes and 30 seconds.

Press the up and down arrow buttons next to the time display to change the run time. Adjustments may be made prior to a run or after a run begins. A quick tap will adjust the time by 30 seconds. Hold down the button for 1 minute adjustments - continue to hold for 5 minute adjustments.

Press the down button once while 00:30 is displayed to access the "hold" feature. When a "hold" run is initiated, the timer will count up to keep track of total run time. The unit will run for a maximum of 99 minutes and 30 seconds and will then shut off automatically. The "hold" run may also be terminated by pressing the STOP/OPEN button. The total run time during a "hold" run is displayed on the time display until the operator unlocks the lid by pressing the OPEN button or opens the lid (during the automatic unlock after the run ends).

Speed Adjustment/ RCF Display

Press the up and down arrow buttons next to the speed display to change the run speed. Adjustments may be made prior to a run or after a run begins. A quick tap will adjust the speed by 50 RPMs. Hold down the button for 100 RPM adjustments. Continue to hold for 500 RPM adjustments.

Press the RCF button at any time to convert the current speed setting to the corresponding force value (xg). The speed may be set by RCF by holding down the RCF button while using the up/down speed set buttons. The jumps made in the RCF value while holding down the RCF button and pressing the up and down arrow buttons correspond to 50 RPM adjustments in speed. Since the RCF is a function of the square of the speed, this jump size will vary.

Starting and Stopping a Run

With the lid switch closed, press the START button to begin a run. Press the STOP/OPEN button at any time during a run to terminate it.

Unlocking the Lid

The lid is unlocked whenever the red UNLOCKED indicator light is illuminated. The lid unlocks automatically for 60 seconds at the end of a run. The lid can also be unlocked for an additional 15 seconds by pressing the OPEN/STOP button while the unit is idle. The lid cannot be unlocked while the rotor is spinning.

Imbalance Detection

This centrifuge is equipped with imbalance detection. If an imbalance is detected, the centrifuge will terminate the current run and will begin to brake to a stop. The words "BALANC" and "ERROR" will flash on the speed display. Once the rotor has stopped, open the lid to cancel the error reporting, balance the load and begin a new run. Alternately, the error reporting can be canceled by pressing the OPEN/STOP button.

Advanced User Settings:

This centrifuge allows for total control of the run by the user. You may adjust the acceleration rate, adjust the braking rate, adjust the imbalance sensitivity level, select from several audible settings, and use the optional countdown delay.

Acceleration Rate - The user may adjust the acceleration rate from minimum (1) to maximum (10) using the following procedure:

1. While the centrifuge is idle, press the PROGRAM button.
2. Use the UP/DOWN arrow buttons next to the speed display until "ACCEL" is displayed in the speed display.
3. The current acceleration rate is displayed in the time display. Use the 'UP/DOWN arrow buttons next to the time display to adjust the acceleration rate from 1 (minimum) to 10 (maximum).
4. Press the PROGRAM button to exit or use the UP/DOWN arrow buttons next to the speed display to adjust additional settings.

Advanced User Settings (continued):

Braking Rate - The user may adjust the braking rate from minimum (slowest deceleration, 0) to maximum (quickest deceleration, 9) using the following procedure:

1. While the centrifuge is idle, press the PROGRAM button.
2. Use the UP/DOWN arrow buttons next to the speed display until “BRAKE” is displayed in the speed display.
3. The current braking rate is displayed in the brake display. Use the UP/DOWN arrow buttons next to the brake display to adjust the braking rate from 0 (minimum) to 9 (maximum).
4. Press the PROGRAM button to exit or use the UP/DOWN arrow buttons next to the speed display to adjust additional settings.

Countdown Delay - When the countdown delay is turned on, the timer will not begin decrementing until the rotor has reached full speed as set by the user. This feature ensures that the samples see full force for the total run time.

1. While the centrifuge is idle, press the PROGRAM button.
2. Use the UP/DOWN arrow buttons next to the speed display until “CNTDLY” is displayed in the speed display.
3. The current status of this feature (ON or OFF) is displayed in the time display. Press UP/DOWN arrows next to the time display to toggle the status between ON and OFF.
4. Press the PROGRAM button to exit or use the UP/DOWN arrow buttons next to the speed display to adjust additional settings.

Imbalance Detection - This centrifuge is equipped with imbalance detection. This ensures that the centrifuge will safely shut down in the event that an imbalanced load is run or a malfunction occurs. This feature is intended to provide for operator safety and to extend the life of the centrifuge. The LOW setting will allow for a greater imbalance before shutting the centrifuge down.

1. While the centrifuge is idle, press the PROGRAM button.
2. Use the UP/DOWN arrow buttons next to the speed display until “BALANC” is displayed in the speed display.
3. The current status of this feature (LOW or HI) is displayed in the time display. Press UP/DOWN arrows next to the time display to toggle the status between LOW and HI.
4. Press the PROGRAM button to exit or use the UP/DOWN arrow buttons next to the speed display to adjust additional settings.

Audible Settings - The user may select from six different audible indicator levels:

<u>Setting</u>	<u>Button Press Beep?</u>	<u>End-of-run audible notification</u>
1	NO	NONE
2	YES	NONE
3	NO	YES, 5 beeps
4	YES	YES, 5 beeps
5	NO	YES, continuous, user must press STOP/OPEN button to cancel
6	YES	YES, continuous, user must press STOP/OPEN button to cancel

1. While the centrifuge is idle, press the PROGRAM button.
2. Use the UP/DOWN arrow buttons next to the speed display until “BEEPER” is displayed in the speed display.
3. The current audible selection is displayed in the time display. Use the UP/DOWN arrow buttons next to the time display to select a setting (1 to 6).
4. Press the PROGRAM button to exit or use the UP/DOWN arrow buttons next to the speed display to adjust additional settings.

Memory Locations / Storing and Recalling:

The Clinispin horizon 755VES centrifuge is capable of storing up to 10 user-defined presets. These memory presets contain all of the settings needed to define a specific run, (run time, speed, acceleration rate, braking rate, etc.). The user can use these memory locations to quickly configure the centrifuge for a specific test type and ensure that the test is run in the same way each time by recalling this same setting.

Store a configuration in a memory location

1. Adjust the various settings (speed, time, acceleration rate, etc.) for the configuration to be saved.
2. Press and hold the PROGRAM button until the preset display begins to flash.
3. Press the MEMORY button to increment the memory location by one. Continue to press the memory button until the desired location is displayed.
4. Press the program button to store the current configuration into the memory location that is displayed.

Recall a configuration from a memory location

1. Press the MEMORY button until the desired memory location is displayed in the memory display.
2. As you review the presets, the settings on the control panel will change to reflect the settings stored in the memory preset currently displayed.
3. When the desired preset is found, pause and the memory display will momentarily flash. The stored configuration is now loaded.

Notes:

Once a configuration has been loaded, it will remain active until any change is made on the control panel. If for instance the user adjusts the time, the current configuration will no longer match the previously loaded configuration and the memory display will change to a “-” dash. The previous configuration may be recalled using the procedure described above.

Memory locations may be overwritten by selecting them during the store procedure.

Cycle Counter:

This centrifuge is equipped with a mechanical cycle counter to monitor machine usage and for routine maintenance. The cycle counter is located on the front of the centrifuge.

CARE AND PREVENTATIVE MAINTENANCE:

With proper care and maintenance your Horizon centrifuge will provide years of laboratory service. For proper care, the following steps should be taken:

1. **Provide Adequate Ventilation:** For cooling purposes, the Horizon draws in ambient air through the air intake cover on the top of the lid and exhausts this air in the rear of the base. The centrifuge should be placed on a hard smooth surface for good air circulation.
2. **Always Spin Balanced Loads:** This centrifuge is equipped with imbalance detection. However, it is still possible to run loads that are minimally imbalanced. Refer to page 8 on balanced loads for additional information on balancing the load.
3. **Keep the Tube Carriers / Holders Clean:** NOTE: Always follow the safety guidelines of your laboratory to properly clean up and/or dispose of materials in the event that a substance known to be potentially toxic, radioactive or contaminated with a pathogenetic microorganism is spilt in or on the centrifuge. Small glass fragments left in the tube carrier / holder after a tube breakage may adhere to the next test tube inserted in that carrier / holder. When this tube is handled, these fragments may puncture protective gloves and lacerate the operator's fingers or hand. Remaining fragments may provide stress points on subsequent tubes and result in additional breakage. If a tube breakage occurs, carefully remove the tube holder. Properly dispose of the sample and tube fragments and thoroughly clean both the inside and outside of the tube carrier / holder. Insert a new tube cushion (if necessary) and replace the tube carrier / holder in the rotor.
4. **Motor and Electrical Maintenance:** This centrifuge uses a brushless-DC motor. There are no brushes to replace and it should not need routine servicing for the life of the centrifuge. The electrical components are selected for high reliability and should not need service.
5. **Keep the Centrifuge Clean:** The cabinet, rotor top and accessories shall be thoroughly cleaned using either isopropyl alcohol, soap and water, or a mild bleach solution. The use of Fully/Partially Halogenated Hydrocarbons, Ketones, Esters and all other chemicals not prescribed by the manufacturer may cause damage to the rotor and tube carriers / holders and should not be used.

If it is necessary to remove the rotor for additional cleaning it is required that a qualified technician remove the outside housing and rotor assembly. Contact Woodley Equipment Company for additional information.

Apply cleaning solutions with a towel or cloth. Do not submerge the centrifuge in water or other cleaning solutions as this will cause damage and void your warranty!

6. **Tube Carrier / Holder Replacement:** Tube carriers are stamped with an expiration date and should be replaced according to this stamp.

TROUBLESHOOTING:

1. Problem: The rotor does not spin freely.

- Solutions:**
- Make sure that nothing has fallen into the rotor chamber.
 - If there is nothing obstructing the rotor, the motor may be damaged. Contact your authorised dealer or Woodley Equipment Company for further assistance.

2. Problem: There is excessive noise when the machine is running.

- Solutions:**
- Check to see that the load is balanced.
 - Make sure that nothing has fallen into the rotor chamber.
 - Make sure that the screw in the center of the rotor is snug.
 - The motor may be damaged. Contact your authorised dealer or Woodley Equipment Company for further assistance.

3. Problem: The centrifuge does not run or an error message is displayed.

- Solutions:**
- Make sure that the centrifuge is getting power. Do the control panel displays come on? Check the electrical outlet that the unit is plugged into. Check the circuit breaker on the base near the rear of the centrifuge.
 - If the unit is getting power, make sure that the lid latch is closed properly. The latch is closed properly when the yellow 'LOCKED' indicator light is illuminated.
 - If the centrifuge stops soon after start-up and 'ERROR' is displayed on the speed display, refer to the following table for fault information:

ERROR / SPEED

The centrifuge cannot reach full speed due to a problem with the rotor, an inadequate power supply, or other electrical problems. Press the OPEN/STOP button to cancel the error and then check the rotor and the line voltage. Contact your authorised dealer or Woodley Equipment Company for further assistance.

ERROR / BALANC

The centrifuge has detected an imbalance. Press the OPEN/STOP button to cancel the error and balance the load. If the load is balanced, make sure that the centrifuge is installed on a secure, level location.

4. Problem: The lid knob cannot be turned / the lid cannot be unlocked.

- Solutions:**
- Make sure the centrifuge has power and that the rotor is stopped. Press the 'OPEN/STOP' button. The red 'UNLOCKED' indicator light should illuminate and the unlocked mechanism should disengage, allowing entry into the rotor chamber.
 - If the lid is still locked, make sure that the red 'UNLOCKED' indicator is illuminated and turn the lid knob first completely clockwise and then counterclockwise.
 - If the red 'UNLOCKED' indicator will not illuminate or the locking mechanism will not disengage, the electronics or locking mechanism may be damaged. Have a technician service the centrifuge or contact Woodley Equipment Company for further assistance.

***For additional assistance, services and technical support
contact Woodley Equipment Company LTD.***

The Clinispin Horizon 755VES complies with all requirements of CE EN 61000-3-2, -3-3, EN 61000-4-2, -4-3, -4-4, -4-5, -4-6, -4-11, EN 61010-1, -2-020 and UL standard 3101-2-20, Can/CSA C22.2 No. 1010.1, Can/CSA C22.2 No. 1010.2.20

SAFETY:

Horizon Lid Safety Switch: The Horizon lid is secured to the top of the cabinet by a latching knob and pawl system. When the knob is rotated clockwise, the pawl grips the underside of the cabinet opening and prevents the lid from opening. A mechanical stop positions the pawl and prevents it from rotating completely. When rotated to the stop position, the pawl makes contact with a micro-switch mounted underneath the cabinet top. The lid safety switch prevents the centrifuge from operating while the lid is open. The yellow 'LOCKED' indicator light on the front of the machine will illuminate when the lid has been latched properly.

Horizon Lid Safety Interlock System: In addition to the Lid Safety Switch, the Horizon has a true "0 RPM" lid locking system. The lid safety interlock system keeps the lid locked at all times, (even during power failure), and requires that the rotor be at rest in order to unlock the lid. The centrifuge will not allow entry into the rotor chamber unless the centrifuge has power and the rotor is stopped. To open the lid, make sure that the centrifuge is plugged in and, with the rotor stopped, press the 'OPEN / EMERGENCY STOP' button.

Note: After the centrifuge has started spinning, it may be possible to rotate the lid knob enough to cause the pawl to lose contact with the lid safety switch. If this happens, the centrifuge motor may lose power, but the lid will still remain locked. If the knob is accidentally moved and this situation should occur, rotate the knob fully clockwise to its stop position and the centrifuge will resume operation.

Circuit Breaker: The Horizon is protected with a 4 Amp circuit breaker located at the rear of the machine mounted to the base. Any electrical short circuit will cause the breaker to cut power to the machine.

Calibration and Earth Ground Testing:

It is recommended that the top speed, ground continuity and line leakage be tested every two years for continued safe operation. Contact Woodley Equipment Company. for further information or testing availability.

Emergency Rotor Chamber Entry:

In the event of power failure, it may be impossible to unlock the lid by conventional means. In this case, entry into the rotor chamber may be made by removing the latch label and using a pen to manually disengage the locking mechanism (see photo). Pull the mechanism towards the control panel and then unlatch and open the lid. If the unit is damaged, contact your authorised dealer or Woodley Equipment Company.



Replacement Parts:

Part No.	Description
7728052	Foot, rubber
7751068	Lid Tray Micro-Switch
7723002	Lid Tray Solenoid
7735016	Motor, 1/2 H.P. Brushless DC
7717041	PC Control Board
3056001	Step Down Transformer
7751043	Circuit Breaker
7724149	Front Panel Label
7760003	Mains lead
7714101	Pawl, lock, lid
7714103	Knob, lock, lid
7712263	Lid
7724071	Hinge, friction
7732009	Gasket, cabinet opening
7732010	Gasket, rotor chamber

6-Place 50mL
Fixed-Angle Rotor
p/n 7786044

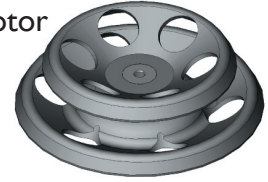

50mL
tube holder
fixed-angle
p/n 7787051

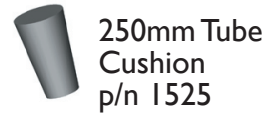

250mm Tube
Cushion
p/n 1525

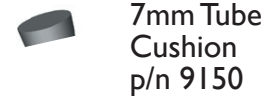

7mm Tube
Cushion
p/n 9150

6-Carrier
Horizontal
Rotor
p/n 7786022

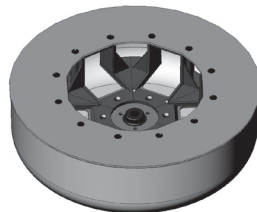

20-Place
Fixed-Angle Rotor
p/n 7786042



4-Place
Carrier
p/n 7713023



Carrier Cap
p/n 7713035



50mL
Carrier
p/n 7713037



125 mm
Tube Holder
p/n 7713044



75 mm
Tube Holder
p/n 7713043



100 mm
Tube Holder
p/n 7713040



Tube
Holder Cap
p/n
7713011

**Contact your authorised dealer or Woodley Equipment Company
to order replacement parts or accessories.**

WOODLEY
EQUIPMENT COMPANY LTD

Made in the USA

Old Station Park Buildings
St. John's Street, Horwich
Bolton BL6 7NY, United Kingdom

Tel: +44 (0) 1204 669033 • Fax: +44 (0) 1204 669034

www.woodleyequipment.com Email: sales@woodleyequipment.com
www.horizoncentrifuges.com Email: sales@horizoncentrifuges.com