



Electrolyte measuring system

SPOTCHEM™ EL

SE-1520 | Operating Manual

Premise

This manual contains important information on the functions of the SPOTCHEM EL SE-1520

This manual is issued by : ARKRAY, Inc.
Read carefully prior to starting up the unit.
It is recommended to retain this manual for future use.

This product conforms to the EMC Standard IEC61326-2-6:2012 (EN61326-2-6:2013).
Class of emission: CISPR 11 Class A
This instrument is an IVD medical instrument.

NOTE: This instrument has been tested and found to comply with the limits for a Class A digital device, pursuant to part 15 of the FCC Rules. These limits are designed to provide reasonable protection against harmful interference when the instrument is operated in a commercial environment. This instrument generates, uses, and can radiate radio frequency energy and, if not installed and used in accordance with the reference manual, may cause harmful interference to radio communications.

Operation of this instrument in a residential area is likely to cause harmful interference in which case the user will be required to correct the interference at his own expense.

The electromagnetic environment should be evaluated prior to operation of the device. Do not use this device in close proximity to sources of strong electromagnetic radiation, as these may interfere with the proper operation.

Introduction

The SPOTCHEM EL SE-1520 is an electrolyte measuring system.

Before operating the SE-1520, please read this manual carefully.

This manual contains outlines, instructions for the operation, maintenance and troubleshooting for the SPOTCHEM EL SE-1520.

Follow the instructions in this manual in order not to defeat the purpose of protective features of the instrument.

Please retain this manual for future reference.

For the purchase of reagents, consumables or other optional items, refer to the after-sales parts and consumables list that comes with the instrument, or contact your distributor.



- **Always be careful when handling blood samples or urine samples. Incorrect or imprecise procedures may result in exposure to pathogenic microbes.**
- **This system must be operated only by those trained in proper procedures for clinical testing and handling of hazardous waste. Trained personnel must assist anyone who operates this system for the first time.**
- **If blood sample is spilt, the user has responsibility for carrying out appropriate decontamination.**
- **Never touch the E-plate, pipetting tip or other places where sample residue may adhere with bare hands. When performing maintenance, always wear protective gloves to prevent exposure to pathogenic microbes.**
- **Separate used samples, E-Plate, pipetting tips and cleaning equipment from general waste and dispose of them according to local regulations on biohazardous waste.**
- **This system may become infectious in the course of use. Discard the product in accordance with local regulations for biohazardous waste.**

Before using any cleaning or decontamination methods except those recommended by the manufacturer, users should check with the manufacturer that the proposed method will not damage the instrument.

All rights reserved. Reproduction of this manual is prohibited.

The contents of this manual are subject to change without prior notice.

Although we take all possible measures to ensure the contents of this manual, please notify your distributor when you have questions, or find errors or omission.

©2001 ARKRAY, Inc.

Notation

The following symbols are used in this manual and labels on this instrument to call your attention to specific items.

■ Regarding accidents resulting in injury or death



To prevent exposure to pathogenic microbes, follow the instructions given herein.



To prevent injury and property damage, follow the instructions given herein.

■ Regarding damage and performance of products

IMPORTANT

To obtain accurate results, to follow the instructions given herein.

NOTE

To prevent damage to the instrument and assist you in making best use of the capabilities of the instrument, additional explanations and notes are provided herein.



Reference information on operation, additional explanations and related functions are provided herein.

Caution Labels

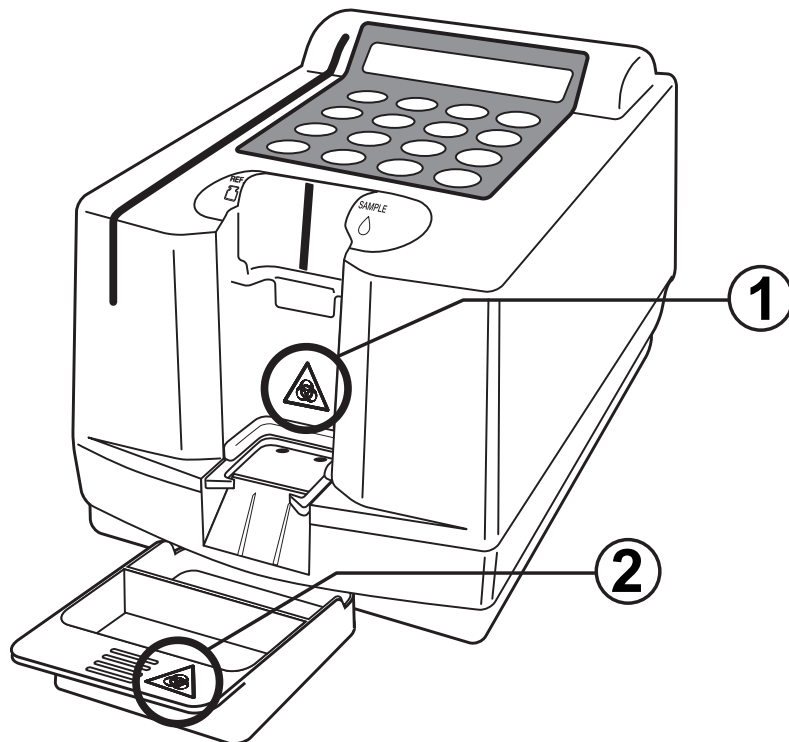

① Plate setting position



Do not touch the Plate setting position with bare hands. When placing reagents or cleaning the area, wear protective gloves to prevent exposure to pathogenic microbes.

② Plate tray



The Plate tray discarding reagents or cleaning the case, wear protective gloves to prevent exposure to pathogenic microbes.

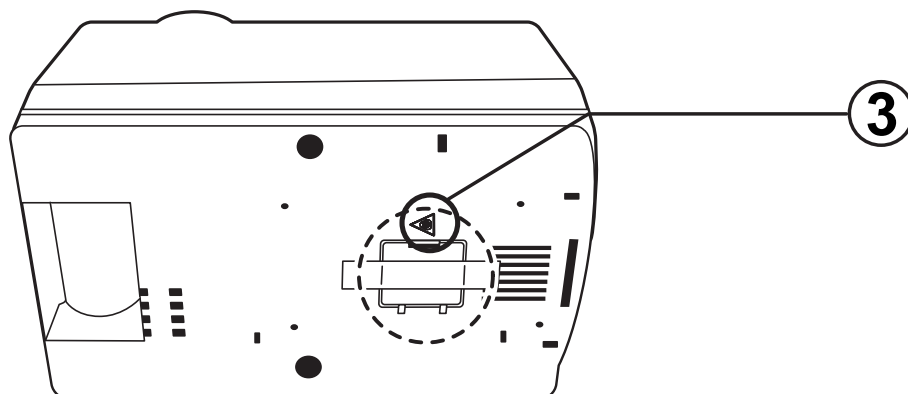

③ Probe pin



Do not touch the probe pin with bare hands. When cleaning the probe pin, wear protective gloves and use swabs to prevent exposure to pathogenic microbes.

Contents

Electrolyte measuring system, SE-1520 Operating Manual

	Premise	1
	Introduction	2
	Notation	3
	Caution Labels	4
	Contents	5
<hr/>		
Chapter 1	1-1 Outline	1-2
Introduction	1-1-1 Features.....	1-2
	1-1-2 Measurement Types.....	1-3
	1-1-3 Measurement Principles	1-3
	1-1-4 Specifications.....	1-4
	1-2 Shipping Carton	1-5
	1-2-1 Shipping Carton (Analyzer and Accessories).....	1-5
	1-3 Parts Description and Function	1-6
	1-3-1 Front of the Analyzer	1-6
	1-3-2 Operator Panel.....	1-7
	1-3-3 Back of the Analyzer	1-8
	1-3-4 Twin Pipette	1-9
	1-3-5 Twin Pipette II	1-10
	1-4 Installation	1-11
	1-4-1 Cautions.....	1-11
	1-4-2 Setting Up	1-13
	1-4-3 First Operation after Installation.....	1-15
	1-4-4 Precautions in Instrument Relocation	1-16
<hr/>		
Chapter 2	2-1 Outline	2-2
Measurement	2-1-1 Operating Procedures.....	2-2
	2-1-2 Exclusive E-Plate	2-3
	2-1-3 Measurement	2-3
	2-1-4 Calibration	2-4
	2-2 Cautions	2-5
	2-2-1 Cautions on Operation	2-5
	2-2-2 Handling Samples.....	2-6
	2-2-3 Handling Exclusive E-Plate.....	2-6
	2-2-4 Handling Magnetic Card	2-7
	2-2-5 Handling Twin Pipette and Twin Pipette II.....	2-7
	2-2-6 Handling Reference Solution	2-9
	2-3 Preparation	2-10
	2-3-1 Preparation	2-10
	2-3-2 Startup	2-11
	2-3-3 Checks before Measurement.....	2-12
	2-3-4 Preparation of Samples	2-14
	2-3-5 Suction of Reference Solution and Samples	2-15

2-4	Measurement	2-18
2-4-1	Normal Measurement	2-18
2-5	Calibration	2-23
2-5-1	Overview	2-23
2-5-2	Magnetic Card Calibration	2-23
2-6	Measurement Result	2-25
2-6-1	Printing the Normal Measurement Results	2-25

Chapter 3 Sub Menu

3-1	Overview.....	3-2
3-1-1	Contents of Each Menu	3-2
3-2	Measurement Results Menu	3-4
3-2-1	Printing Measurement Results	3-4
3-2-2	Transmitting Measurement Results	3-6
3-2-3	Deleting Measurement Results	3-8
3-2-4	Wildcards	3-9
3-3	Parameter Menu.....	3-10
3-3-1	Printing Parameters	3-10
3-3-2	Entering Parameters	3-12
3-3-3	Initializing Parameters.....	3-14
3-4	Maintenance Menu	3-16
3-4-1	Cleaning the Probe	3-16
3-4-2	Cleaning the Table	3-16
3-4-3	Check Measurement.....	3-16
3-5	Mode Menu	3-17
3-5-1	Survey Mode.....	3-17
3-6	Built-in Clock Adjustment.....	3-18

Chapter 4 Maintenance

4-1	Outline	4-2
4-1-1	Frequency of Maintenance	4-2
4-2	Daily Maintenance	4-3
4-2-1	Cleaning the Plate Tray.....	4-3
4-2-2	Cleaning the Plate Transfer Part.....	4-3
4-3	Periodical Maintenance.....	4-4
4-3-1	Replacement of Thermal Printer Paper.....	4-4
4-3-2	Cleaning the Probe	4-6
4-3-3	Cleaning the Twin Pipette II	4-8
4-3-4	Replacement of Nozzle O-ring	4-9

Chapter 5 Troubleshooting

5-1	Error Messages.....	5-2
5-2	Trouble Messages	5-5

Chapter 6 Appendix

6-1	Transmission Specifications	6-2
6-1-1	External Output Format.....	6-2
6-1-2	Block Structure.....	6-3
6-1-3	Format of Measurement Results.....	6-4
6-2	After-sales Service	6-5

MEMO

Chapter 1

Introduction

The SPOTCHEM EL SE-1520 is an electrolyte measurement system using a exclusive E-Plate.

Chapter 1 contains functions and measurement principles of SE-1520.

1-1 Outline

- 1-1-1 Features
- 1-1-2 Measurement Types
- 1-1-3 Measurement Principles
- 1-1-4 Specifications

1-2 Shipping Carton

- 1-2-1 Shipping Carton (Analyzer and Accessories)

1-3 Parts Description and Function

- 1-3-1 Front of the Analyzer
- 1-3-2 Operator Panel
- 1-3-3 Back of the Analyzer
- 1-3-4 Twin Pipette
- 1-3-5 Twin Pipette II

1-4 Installation

- 1-4-1 Cautions
- 1-4-2 Setting Up
- 1-4-3 First Operation after Installation
- 1-4-4 Precautions in Instrument Relocation



1-1-1 Features

The SPOTCHEM EL SE-1520 is an electrolyte measurement system that uses a disposable ion selectivity electrode. It is suitable for immediate tests performed in clinics and small to large hospitals.

Simple and fast settings in an emergency

- The ion selectivity electrode enables simultaneous measurement of basic three items (Na^+ , K^+ , and Cl^-).
- By adopting a pipette support structure for the analyzer, pipetting to the disposable electrode (exclusive plate) is easy.
- Auto-start function starts measurement just after exclusive plate setting and pipetting with the twin pipette.
- By using the twin pipette II (trade name), which continuously distributes reference solution, sampling operation is not needed each time, so measurements are done more easily.

Compact design

- The size is as small as that of an A5 sized paper. The small unit contains various components such as a display, printer, measurement devices and flash memory.

Up to 50 measurement results can be stored.

- A maximum of 50 measurement results can be stored. Data is automatically deleted from the oldest data when stored data exceeds 50 samples.

Hand-held barcode reader can be used.

- A hand-held barcode reader can be used (optional). Each read barcode data is allocated ID as a measurement result.

1-1-2 Measurement Types

- **Normal Measurement**

A (normal) sample is measured.-The measurement result is identified by the measurement number indicated as “No. XXXX”, which is automatically updated. When power is turned on measurement number is set at “No. 0001” and it increases sequentially until the power is turned off.
- **Check Measurement**

Exclusive “check plate” is used for Check Measurement, it be able to control the precision and the result is output. Maintenance of the device is required, depending on the result.

1-1-3 Measurement Principles

The SPOTCHEM EL SE-1520 adopts a potentiometry method of ion selective membrane electrode as its principle, which provides measurement for various ion concentrations in body fluid. The construction of the ion selective electrode used for electrolyte measurement as follows.

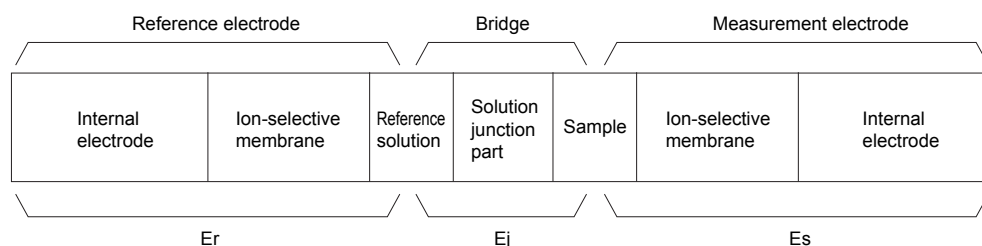

The identical structure of ion selective electrode is used for both reference electrode and measurement electrode. When reference solution is measured with the reference electrode, electric potential of reference electrode E_r is obtained. Also, when the desired ion in measurement solution is measured with the measurement electrode, electric potential of measurement E_s is obtained.

By setting up a solution junction part between the reference and measurement solutions, measurement electric potential E is obtained between the reference electrode and measurement electrode. There is a relation of Nernst equation between generated electric potential and ion activity (ion concentration). Ion concentration is obtained by measuring potential difference E .

$$E = E_s - E_r + E_j$$

$$E = \frac{2.303RT}{ZF} (\log (a_s) - \log (a_r)) + E_j$$

$$E = \frac{2.303RT}{ZF} \log (a_s) + E_0$$

[note]

E_s : Electric potential by ion activity in sample

E_r : Electric potential by ion activity in reference solution constant)

E_j : Electric potential of solution junction (constant)

$$E_0 : E_j - \frac{2.303RT}{ZF} \log (a_r) \quad (\text{constant})$$

a_s : Ion activity in sample

a_r : Ion activity in reference solution constant)

1-1-4 Specifications

Sample	Whole blood, Serum, Plasma, Urine
Measurement item	Na ⁺ , K ⁺ , Cl ⁻
Measurement principle	Potentiometric method with ion selective electrodes
Measurement time	Approx. 1 minute
Consumed sample	22μL
Sample supply	Manual pipetting by twin pipette
Incubation temperature	32°C
Display	LCD (20 characters x 2 lines)
Built-in printer	36-character thermal printer (Paper width: 58mm)
External output	RS-232C interface (serial)
Transmission method	One-way/two-way transmission
Transmission speed	9600bps
Memory	50 measurements
Measurement conditions	Temperature: 10-30°C, Humidity: 20-80% RH (Non-condensing)
Environment during transport	Temperature: -10-60°C Humidity: 20-80% RH (Non-condensing)
Storage environment	Temperature 1-30°C Humidity: 20-80% RH (Non-condensing)
Power supply	AC100-240V (Main power supply voltage variation must be within ±10%), 50/60Hz
Power consumption	40VA
Dimensions and weight	Dimensions: 135(W) x 225 (D) x 138 (H) Weight: Approx 1.5kg (Analyzer only)
Sound pressure level	Less than 85 dB
Location of use	Indoor use only
Altitude	2,000 m
Pollution degree	2
Over voltage category	II
Expected life	5 years (according to company data)

1-2 Shipping Carton

1-2-1 Shipping Carton (Analyzer and Accessories)

The following items are included with this instrument. Check that all of these items are included. If any items are missing or defective, please contact your distributor.

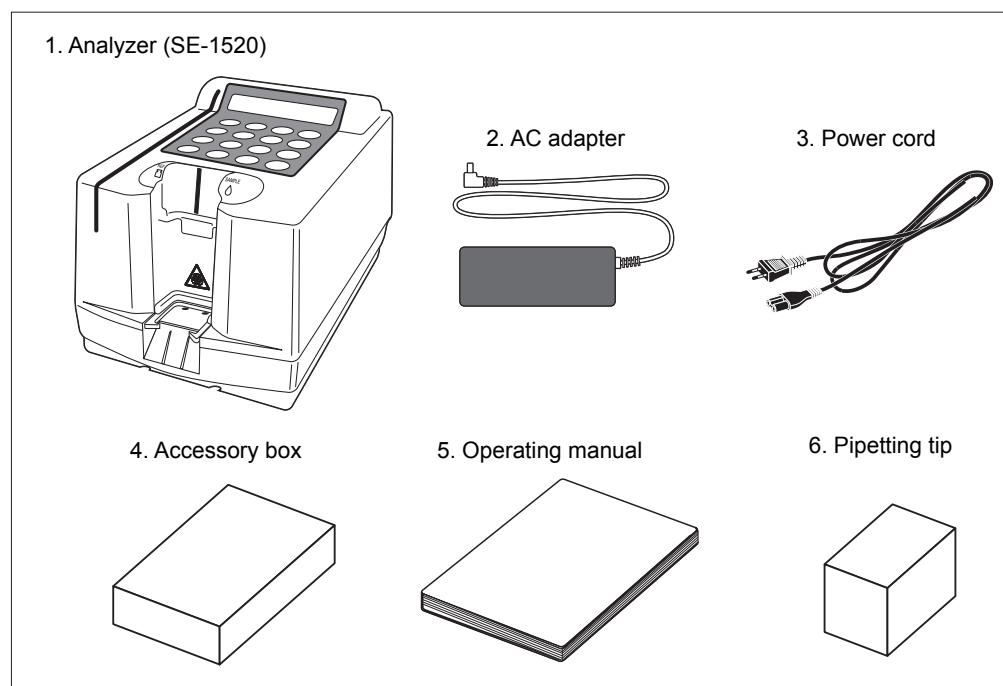

Analyzer

No.	Item	Description	Amount
1	Analyzer	SE-1520 (SPOTCHEM EL)	1unit
2	AC adapter		1unit
3	Power cord		1unit
4	Accessory box		1box
5	Operating manual	This booklet	1copy
6	Pipetting tip	100pcs.	1box

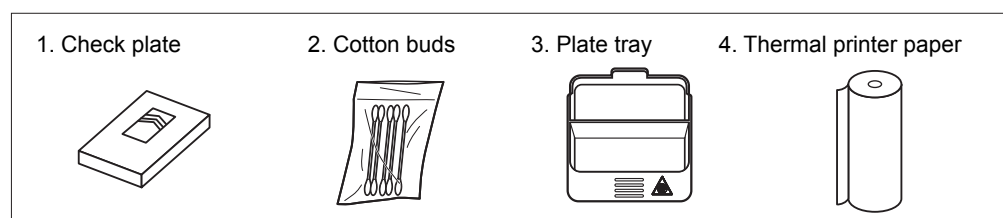

Accessory box

No.	Item	Description	Amount
1	Check plate	1sheet	1unit
2	Cotton buds	5pcs.	1set
3	Plate tray		1unit
4	Thermal printer paper		1roll

1-3 Parts Description and Function

1-3-1 Front of the Analyzer

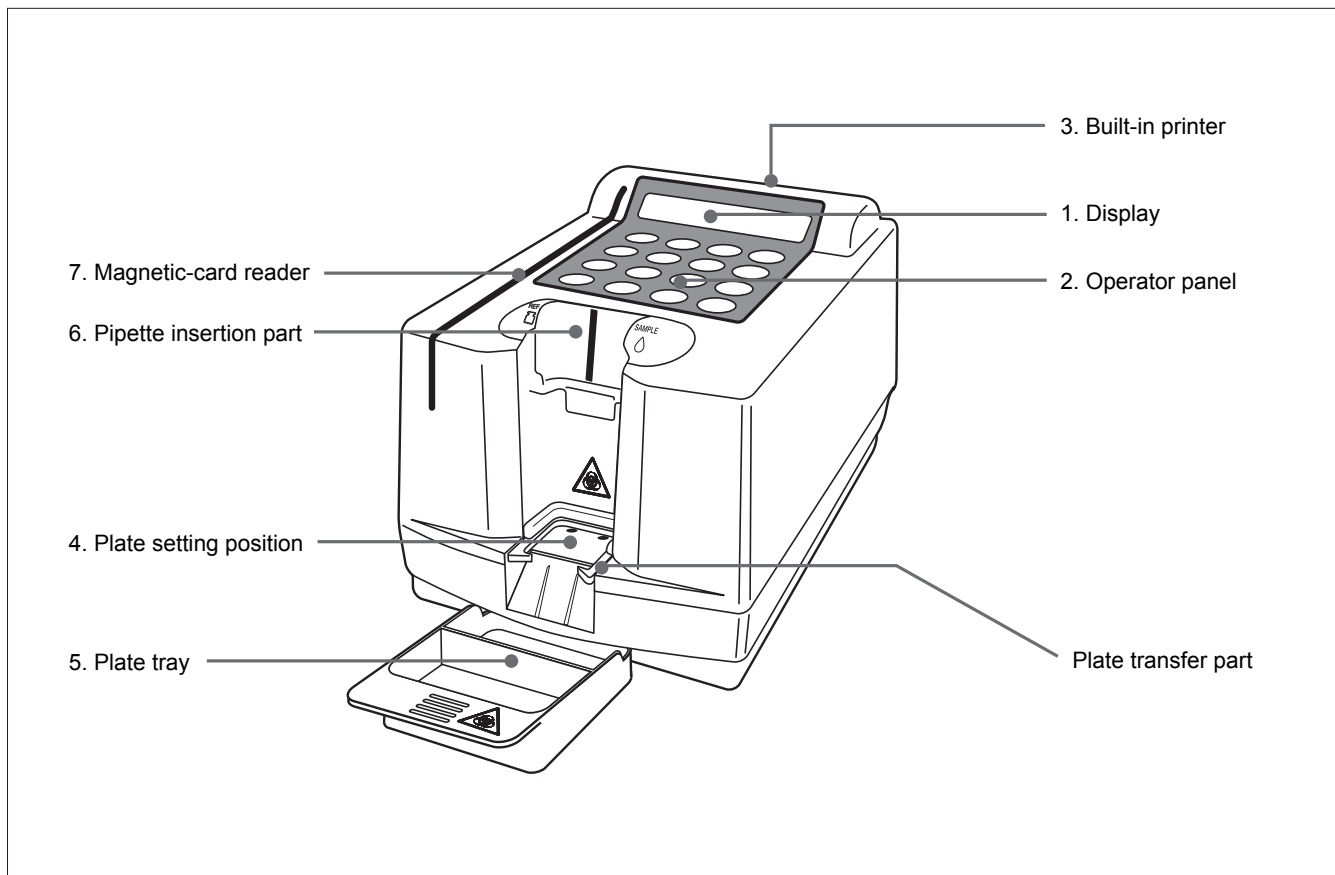

No.	Item	Functions
1	Display	Displays information, such as operating state of the unit and error messages.
2	Operator panel	Start or Stop measurement, and enter various kinds of values.
3	Built-in printer	Thermal line printer for printing out measurement results and parameter settings.
4	Plate setting position	Set the exclusive E-plate.
5	Plate tray	Used plate is discarded.
6	Pipette insertion part	Insert position for pipetting samples
7	Magnetic-card reader	Insert magnetic card, if a new item is added or lot card is loaded

1-3-2 Operator Panel

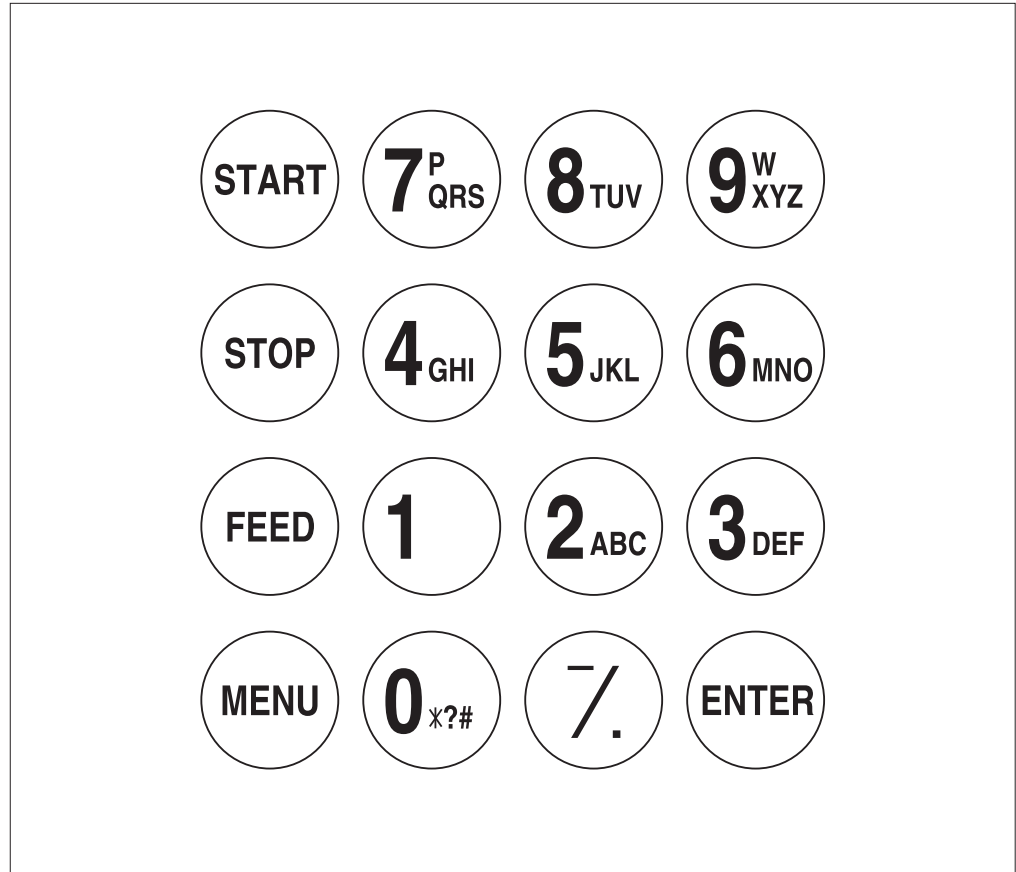

Item	Functions
START	Start measurement. Select "Yes" from the Yes/No option.
STOP	Stop measurement or Cancel the entry. Select "No" from the Yes/No option.
FEED	Feed paper the built-in printer into the built-in printer while being pressed.
MENU	Switch the page on each menu display.
0 - 9 (numeric keys)	Enter alphanumeric characters and symbols.
- / . (hyphen/period)	Select items, move the cursor, switch the pages on the display, and enter minus sign and decimal point.
ENTER	Confirm the entry. Check message to move on to the next operation.

1-3-3 Back of the Analyzer

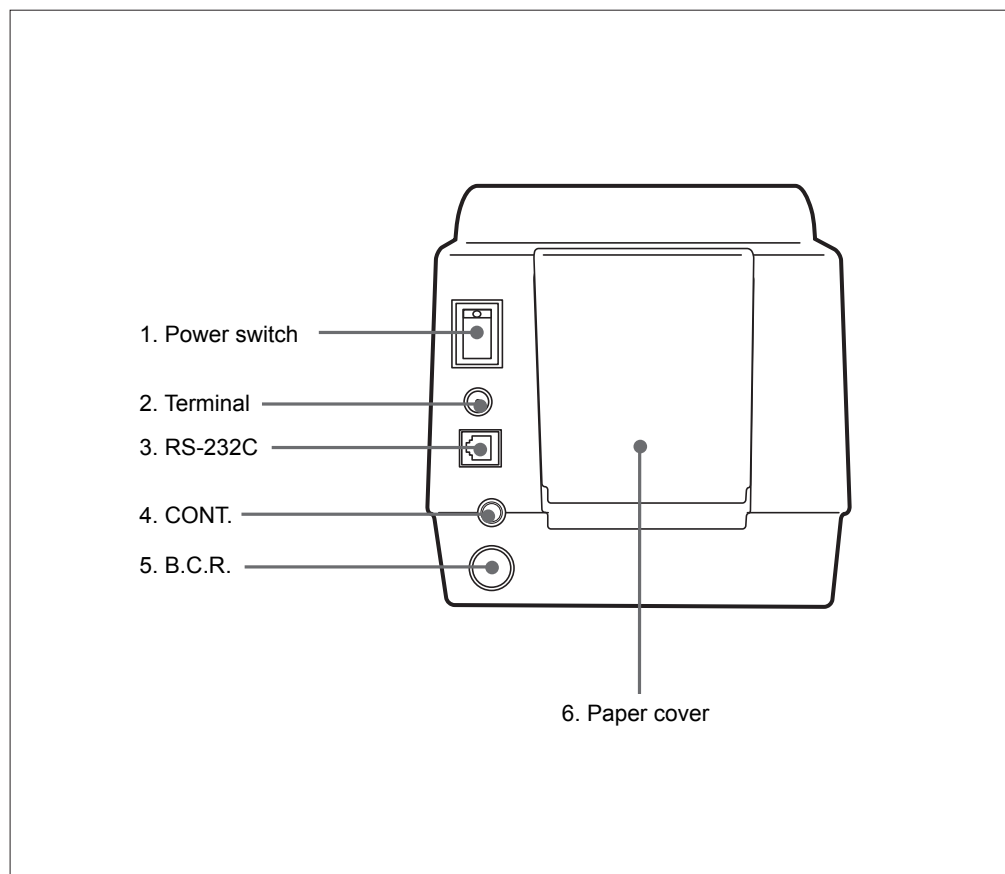

No.	Item	Functions
1	Power switch	Turn on/off the power.
2	Terminal	Connect with the attached AC adapter.
3	RS-232C	Connect with the cable of external device.
4	CONT.	Adjust the contrast on the display. To enhance the contrast, turn the knob clockwise; to attenuate it, counterclockwise.
5	B.C.R.	Connect with handy barcode reader.(optional)
6	Paper cover	Open this part to exchange thermal paper.

1-3-4 Twin Pipette

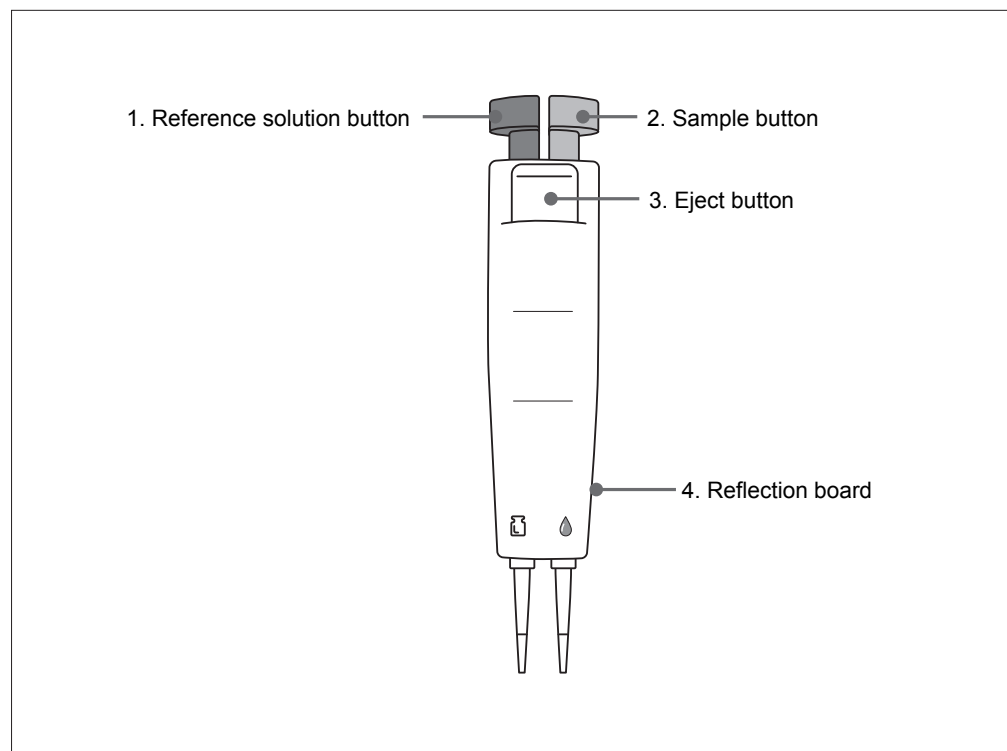

No.	Item	Functions
1	Reference solution button	Suction and discharge of reference solution
2	Sample button	Suction and discharge of sample
3	Eject button	Detachment of pipetting tip
4	Reflection board	Informs the system of the condition of pipette operation in the event of sampling

1-3-5 Twin Pipette II

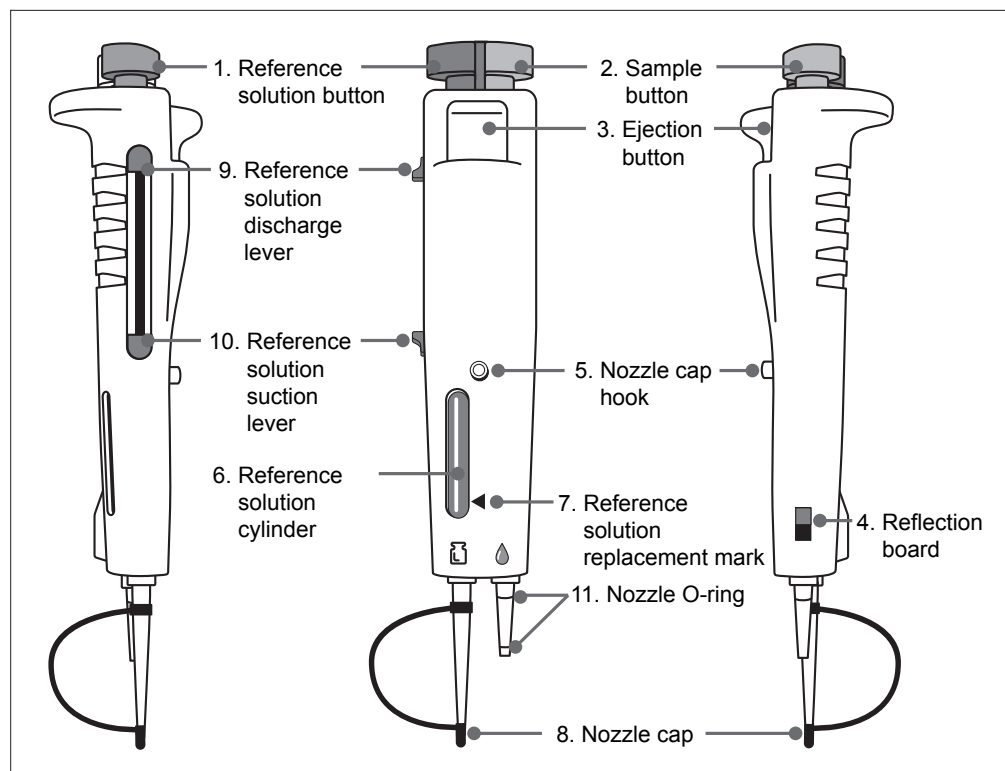

No.	Item	Functions
1	Reference solution button	Suction and discharge of reference solution
2	Sample button	Suction and discharge of sample
3	Ejection button	Detachment of pipette tip
4	Reflection board	Informs the system of the condition of pipette operation in the event of sampling
5	Nozzle cap hook	Removed caps can be inserted and fixed here.
6	Reference solution cylinder	Drawn up reference solution enters here.
7	Reference solution replacement mark	Mark to see the residual quantity of reference solution in the cylinder. If the solution amount doesn't reach the mark, replace reference solution.
8	Nozzle cap	Protection of reference solution nozzle tip and prevention of evaporation when not used.
9	Reference solution discharge lever	Push down the lever when reference solution in the cylinder is discharged.
10	Reference solution suction lever	Push down the lever when reference solution in the cylinder is drawn up.
11	Nozzle O-ring	Fix the attached pipetting tip

1-4 Installation

1-4-1 Cautions



Before setting up the analyzer, read the following notes and always take proper safety precautions.

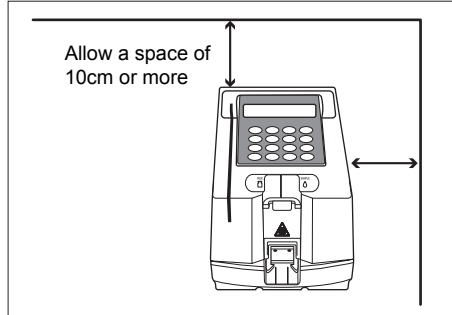

- Allow a space of 10 cm or more between the rear of the analyzer and the wall. Failure to do so may cause overheating. Excessive load on the cable connection may cause fire. Correct measurement results may not be obtained. Also, you will have trouble trying to turn off the power switch and disconnect connectors in the event of errors or trouble.

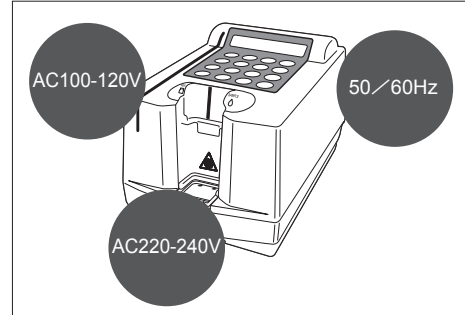

- Operate the analyzer with power of the correct voltage and frequency. Otherwise it may cause fire or give some damage to the analyzer.

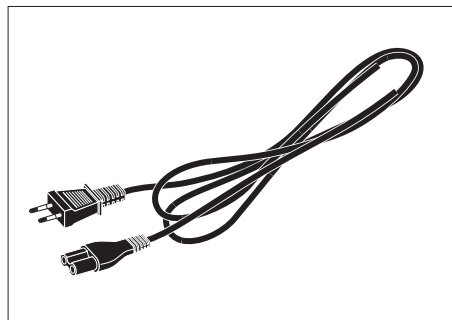

- To avoid electric shock and/or fire, use the attached power cord only to connect with a power outlet.

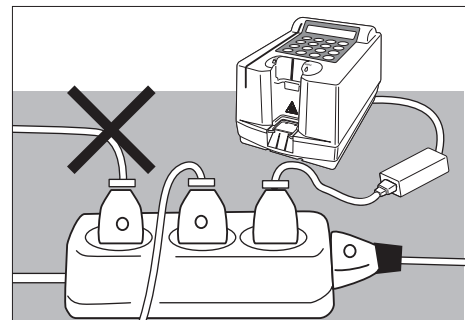

- Connect the power plug directly to an outlet, not via an extension cord or power tap. The power supply for the analyzer is 40 VA.

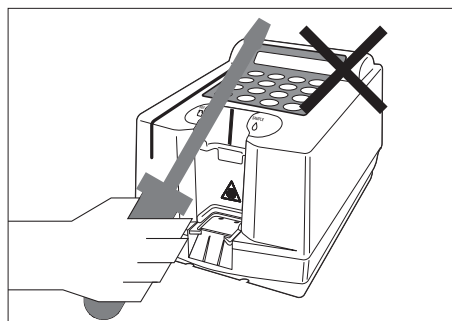

- Do NOT unnecessarily disassemble or modify the analyzer. Such actions may cause danger of exposure to pathogenic microbes, fire or damage.



- Place the analyzer on a stable and level surface free from vibration. Failure to do so may damage the analyzer, correct measurement results may not be obtained, or cause injury.



Before setting up the analyzer, read the following notes and always take proper safety precautions.

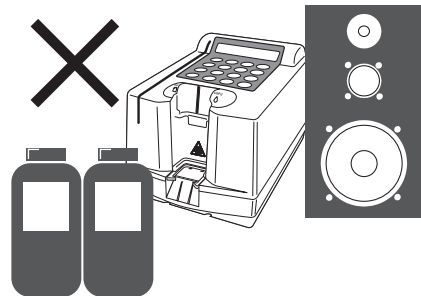

- Do NOT set the analyzer where chemicals are stored nearby, or where corrosive gases or electrical noise are generated. They may damage the analyzer, and malfunctions and/or injury may occur. Correct measurement results may not be obtained.

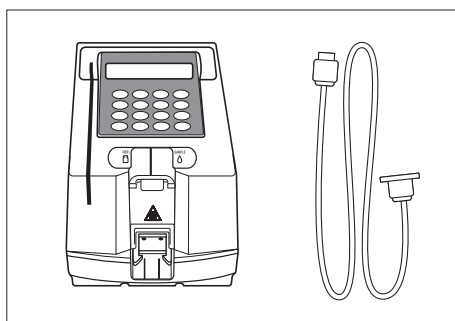

- To connect the analyzer to external devices, be sure to use proper cables to avoid electric shock and/or fire. For details, contact your distributor.

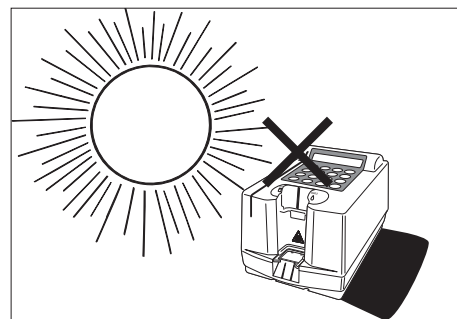

- Avoid exposing the analyzer to humidity, air containing sulfur, direct sunlight or wind, etc. Otherwise correct measurement results may not be obtained, and it may cause deformation or malfunction of the analyzer.

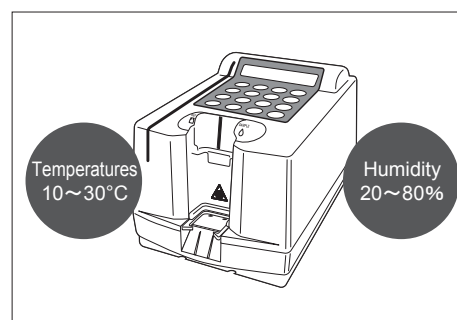

- Place the analyzer in a room at temperatures between 10°C and 30°C with humidity between 20% and 80%. Otherwise, correct measurement results may not be obtained.

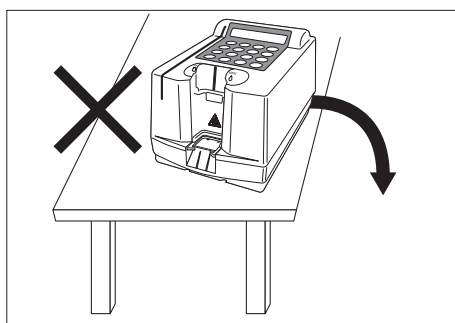

- Be careful not to drop the unit from the table.

1-4-2 Setting Up

Various parts are fixed by tapes or screws in order to avoid scratches or breakage during transportation. Remove these fixtures before setting up the unit.

Read carefully “1-4-1 Cautions.”



To connect the system to external devices, be sure to use proper cables to avoid electric shock or fire. For details, contact your distributor.

Required items

Analyzer, AC adapter, power cord, exclusive cable (for communication external)

1. Remove the fixing tape on the maintenance cover

- Remove the fixing tape adhered to the maintenance cover the bottom of the analyzer.

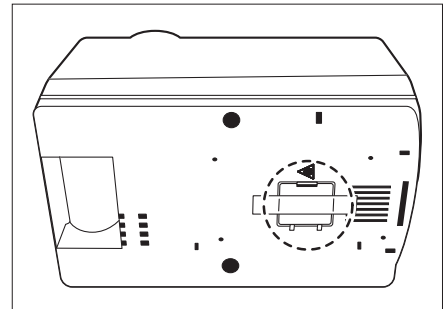

2. Remove the fixing tape on the paper cover

- Remove the fixing tape adhered to the paper cover on the back of the analyzer.

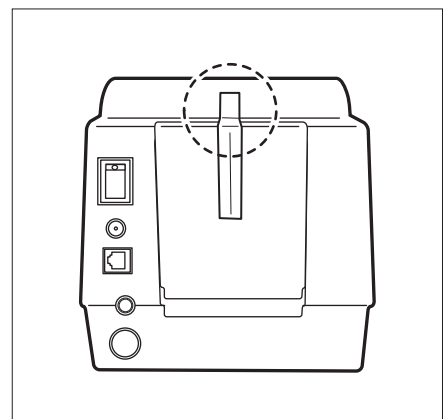

3. Plug in the power cord

- Connect the AC adapter to the power cord.
- Make sure that the power switch on the rear of analyzer is OFF.
- Connect the AC adapter to the receptacle on the rear of analyzer, and plug the other end of the cord into the AC outlet.

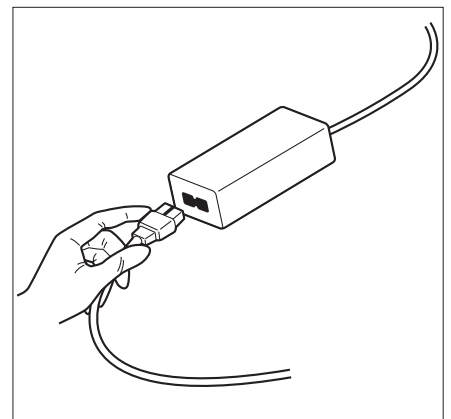
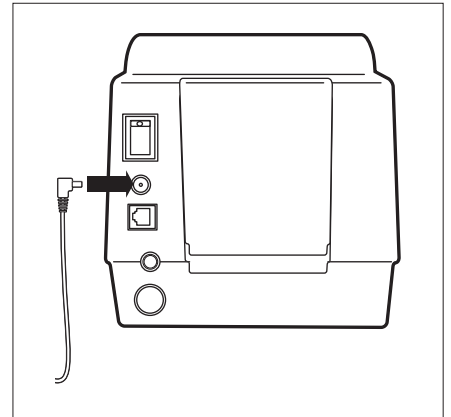

► Connect the exclusive cable when using an external device. (connecting cable is optional)

4. Connect to an external device (if necessary)

- Plug the connecting cable with the external device into the external input/output terminal.

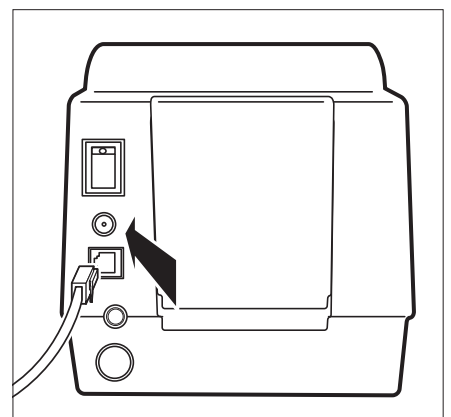

1-4-3 First Operation after Installation

- ▶ The name of analyzer and its version number are displayed and self-diagnosis starts in 5 seconds. The internal memory is checked on abnormal conditions.
- ▶ If an error or a trouble message appears on the display, something is wrong with the internal memory. Turn off the power and contact your distributor.
- ▶ The internal mechanisms of analyzer are initialized. Do NOT touch the plate transfer part when it moves. Otherwise it may damage analyzer or cause injury.

This section explains the operation of analyzer, setting of thermal printer paper and entering data and time.

Turn on the power to activate the plate transfer part to be set at its ready position.

1. Turn on the power

- Turn on the power on the rear of analyzer.
- About 1 minute after (room temperature at 25°C), warm-up is completed and the MAIN MENU is displayed.

SPOTCHEM EL
SE-1520 V1. XXX

Initializing... /

Warming up... /

1. Measure 2. Submenu
3. Cal. (1/1)

2. Adjust the contrast of display

- Adjust the contrast of the display by turning the contrast controller on the rear of the analyzer.
To enhance the contrast, turn the knob clockwise; to attenuate it, turn it counterclockwise.

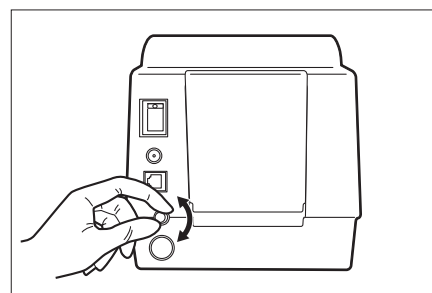

3. Set thermal printer paper

- Set the attached thermal printer paper (see 4-3-1 “Replacement of Thermal Printer Paper”).

4. Set the Date and Time

- Set the date and time (see 3-6 “Built-in Clock Adjustment”)

5. Turn off the power

- Turn off the power after making sure that the MAIN MENU is displayed, when discontinuing operation or setting after setting thermal printer paper and setting the date and time.

1-4-4 Precautions in Instrument Relocation

Read the precautions below carefully and always be mindful of safety when transporting the system.

- Turn off the power and disconnect the power cable before transporting the system. Failure to do so may cause system malfunction.
- When transporting the system, handle the system with both hands and avoid exposing the system to impacts or vibrations. Failure to do so may cause system malfunction.
- Remove the waste tray before transporting the system. Accidental detachment of the waste tray or waste reagent on the tray may cause pathogenic microbial contamination.

Chapter 2

Measurement

The SE-1520 is capable of sample measurement. Chapter 2 explains the procedures and outline of each measurement.

2-1 Outline

- 2-1-1 Operating Procedures
- 2-1-2 Exclusive E-Plate
- 2-1-3 Measurement
- 2-1-4 Calibration

2-2 Cautions

- 2-2-1 Cautions on Operation
- 2-2-2 Handling Samples
- 2-2-3 Handling Exclusive E-Plates
- 2-2-4 Handling Magnetic Card
- 2-2-5 Handling Twin Pipette and Twin Pipette II
- 2-2-6 Handling Reference Solution

2-3 Preparation

- 2-3-1 Preparation
- 2-3-2 Startup
- 2-3-3 Checks before Measurement
- 2-3-4 Preparation of Samples
- 2-3-5 Suction of Reference Solution and Samples

2-4 Measurement

- 2-4-1 Normal Measurement

2-5 Calibration

- 2-5-1 Overview
- 2-5-2 Magnetic Card Calibration

2-6 Measurement Result

- 2-6-1 Printing the Normal Measurement Results



2-1 Outline

2-1-1 Operating Procedures

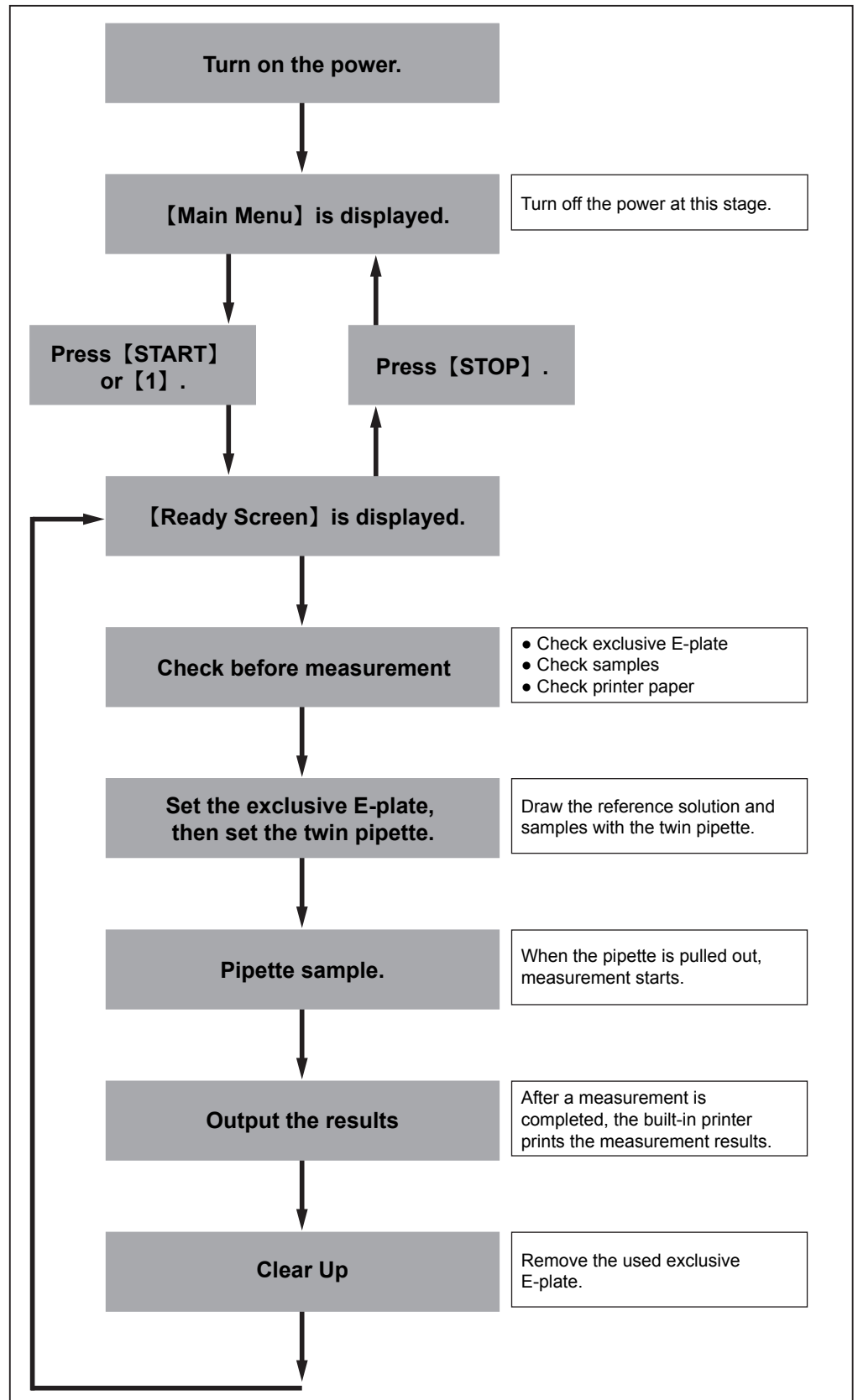

2-1-2 Exclusive E-Plate

Exclusive E-Plate is used for this analyzer(sold separately).
Exclusive E-Plates is available for each measurement item.

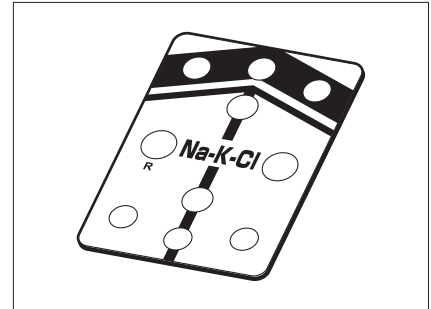

2-1-3 Measurement

With this analyzer, normal measurement and check measurement are available.

Normal measurement is used to measure the exclusive plate and check measurement is the mode to measure the attached check plate.

■ Normal Measurement

Press [1] key on the Main Menu to enter the Normal Measurement Mode for sample measurement.

Measurement results are identified by the measurement number indicated as "No. XXXX", which is updated automatically and given sequent number until the power is turned off.

■ Check Measurement

The attached check plate is measured to confirm that the measurement function of the system is working normally. Run this measurement when a false measurement result is obtained.

2-1-4 Calibration

Calibration is performed in the form of “calibration by magnetic card” using magnetic card.
For details, see 2-5-1“Overview”.

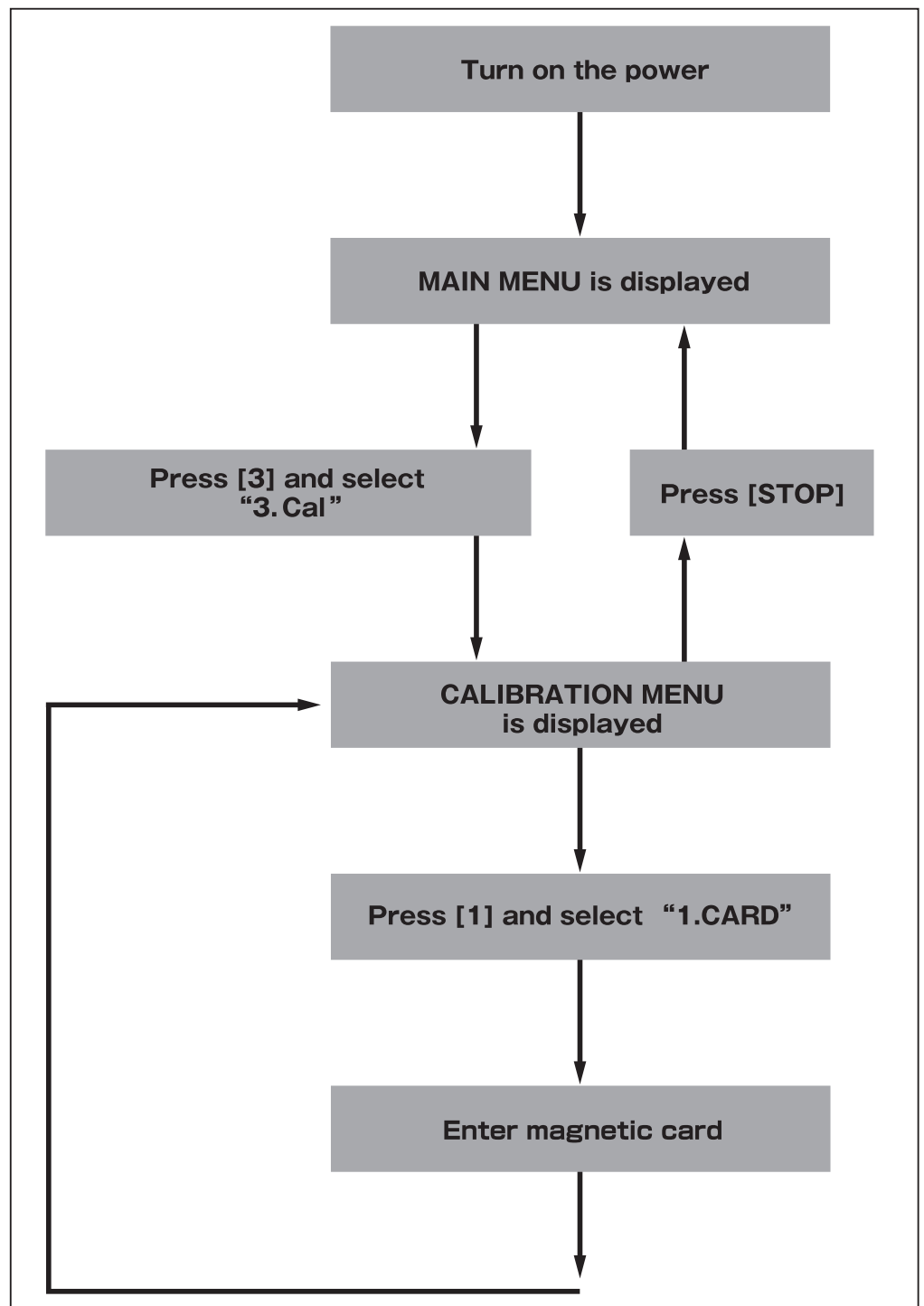

2-2 Cautions

2-2-1 Cautions on Operation

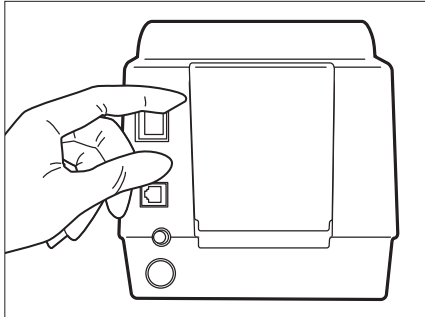

- Before turning on the power, be sure to read 1-4-1 “Cautions” again and operate the analyzer in a proper environment.

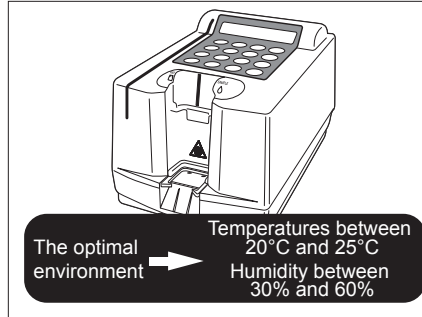

- The temperature controlling function works to obtain accurate measurement results under temperatures between 10 °C and 30°C. However, it is recommended to perform measurement in the optimal environment at temperatures between 20°C and 25°C with humidity between 30% and 60% for more accurate measurement results.

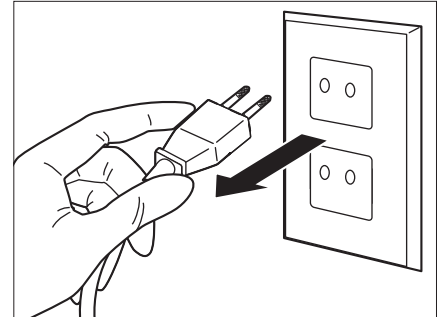

- If you find any abnormal operation, odor or smoke, turn off the power immediately and unplug the analyzer. There may be danger of damage to the analyzer, injury or fire.

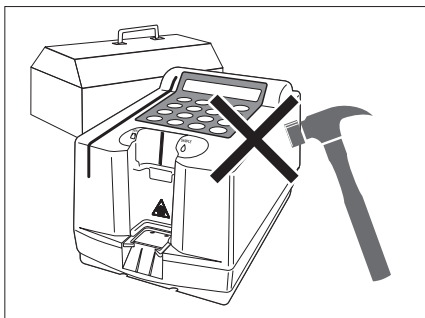

- In case of malfunction, contact your distributor for repair. Do NOT attempt to repair or remodel the analyzer yourself. It may result in damaging the analyzer or injury.

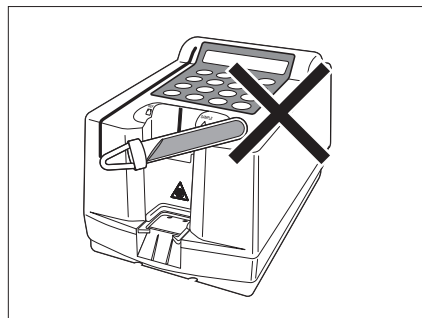

- Do NOT place bottles containing samples on the analyzer. They may tip over and leak into the inside of the analyzer resulting in damage.

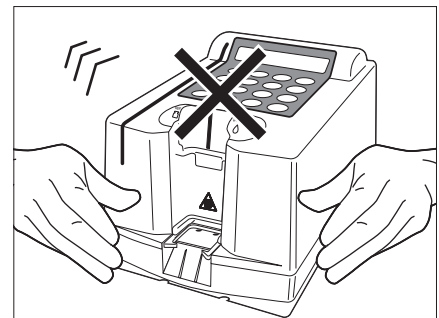

- Do NOT move the analyzer during measurement. Vibration to the analyzer during measurement may cause malfunction and incorrect measurement results.

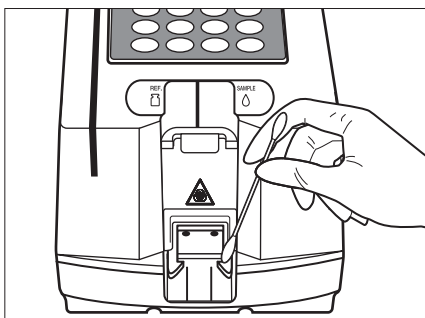

- Make sure to provide proper maintenance of the parts in order to keep measurement accuracy.

2-2-2 Handling Samples

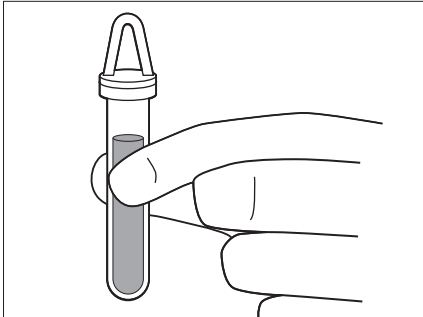

- Whole blood, serum, plasma also urine are used as samples with this analyzer. Be aware that they may be contaminated with pathogenic microbes that may cause infectious disease. Use protective gloves or take other preventive measures with extreme caution when handling these samples. Incorrect or imprecise procedures may result in exposure of the operator and other persons nearby to pathogenic microbes

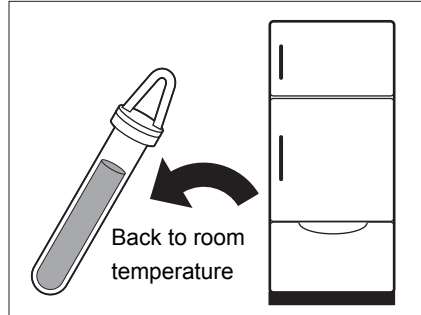

- Prepare fresh blood (within 1 hour after collection) and fresh urine. Allow refrigerated blood samples back to the room temperature before measurement.

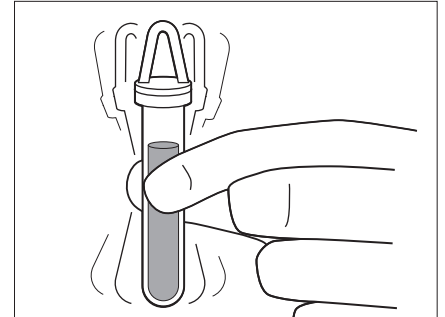

- Stir sample without foaming then distribute it before starting the measurement.

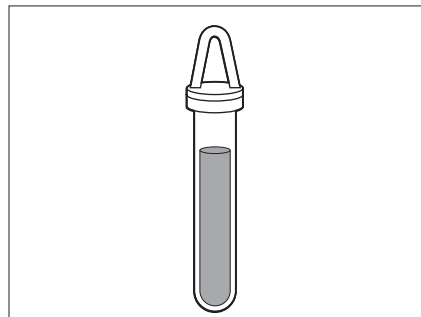

- Distribute sample in a specified volume.

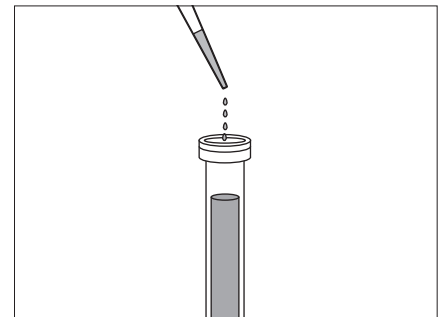

- When measuring a urine sample, use a two-fold dilution made with refine water. If the sample still exceeds the measurable range, dilute it again and double the obtained measurement value.

2-2-3 Handling Exclusive E-Plate

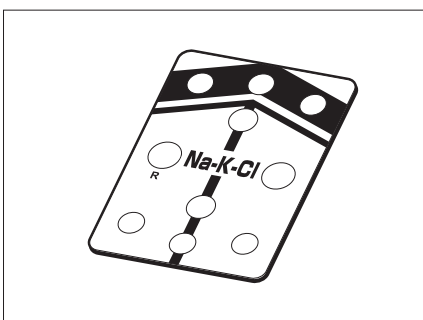

- Use exclusive E-Plate. Read the notes attached to each E-Plate and use it before the expiry date.

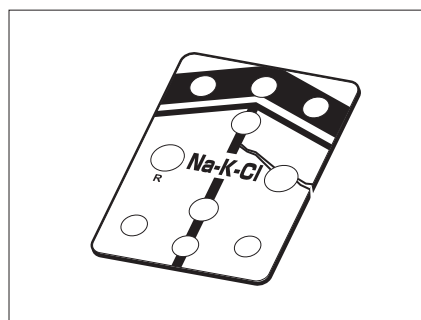

- Check before use. Do NOT use exclusive E-Plate that are cracked or leaked even prior to the expiry date.

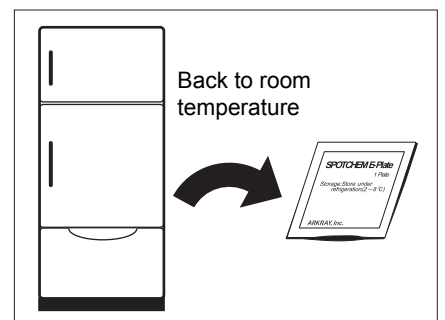

- Prepare exclusive E-Plate before measurement. Necessary number of exclusive E-Plate should be taken out of the refrigerator to allow them to reach room temperature before measurement.

2-2-4 Handling Magnetic Card

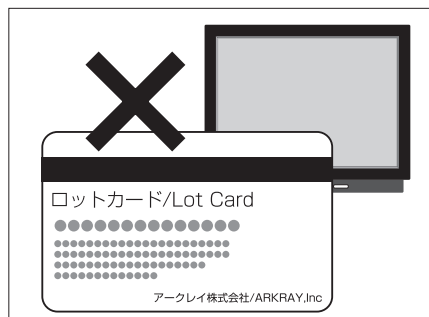

- Do NOT place magnetic cards near magnetic objects (magnets, TV sets, etc) otherwise. The information stored on the card may become unreadable with the magnetic card reader.

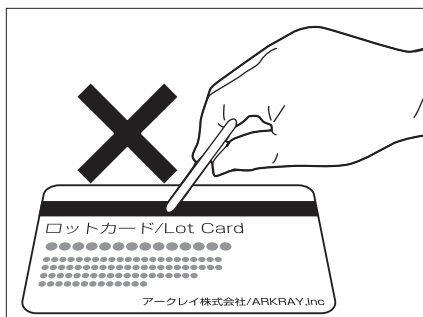

- Do NOT scratch the magnetic surface (stripe). The information stored on the card may become unreadable with the magnetic card reader.

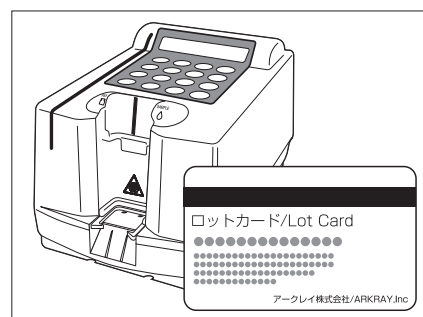

- Do NOT use the magnetic card attached to the exclusive E-Plate for other devices or machines except for SE-1520. The card may get stuck.

2-2-5 Handling Twin Pipette and Twin Pipette II



Do NOT use the twin pipette (for SE-1510) with reflection board on the both sides of it.

1. Use the exclusive pipette.

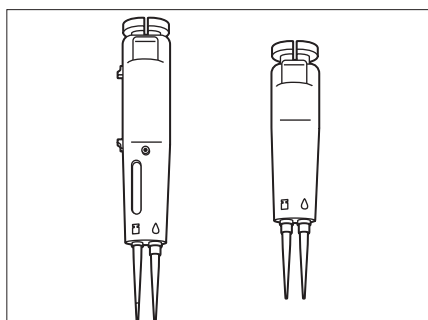

- Use either the exclusive twin pipette or the twin pipette II. Do NOT use pipetting tips other than the exclusive one. By using a soft cloth or swab, wipe off the dust or dirt from the Tip fitting part (e.g. O-ring) of twin pipette or twin pipette II, if necessary.

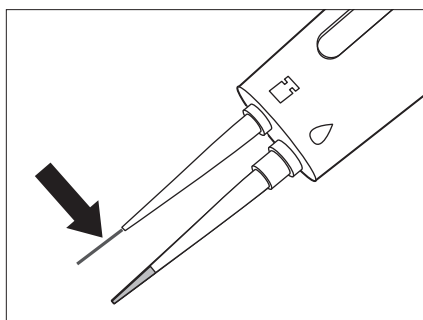

- The nozzle tip of twin pipette II for the reference solution is narrow and sharp: it can be damaged easily and also may cause injury by scratching or sticking. Be careful in handling and do not handle it roughly.

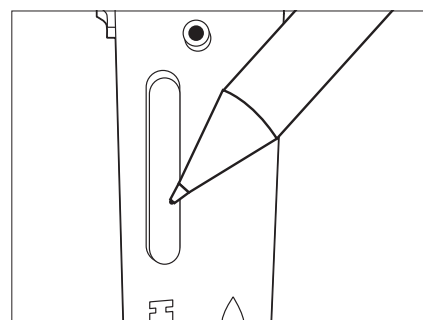

Do NOT place things in the cylinder window of the pipette or push the cylinder window with a ball-point pen or other objects. Do NOT drop the pipette. Cylinder breakage may cause injury.

2. Check before use when using twin pipette

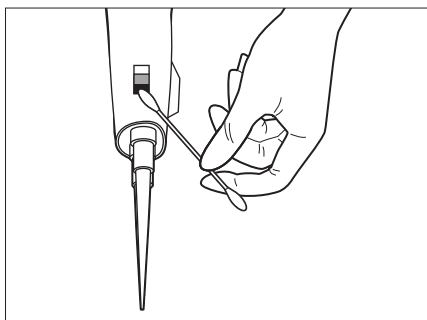

- Check the "Reflection board".
If the "Reflection board" on the lower part of the pipette (shiny aluminum board) is stained, wipe off the stain to avoid incorrect measurement.

when using twin pipette II

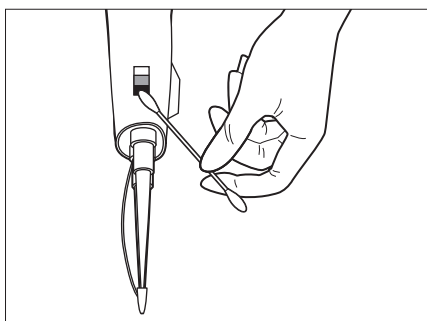

- Check the "Reflection board".
If the "Reflection board" on the lower part of the pipette (shiny aluminum board) is stained, wipe off the stain to avoid incorrect measurement.

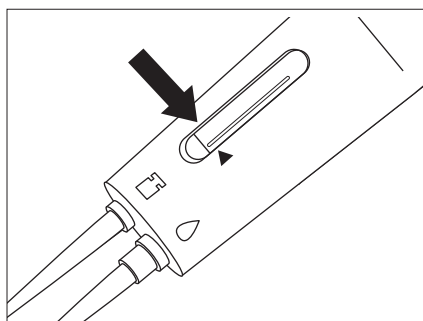

- Check the reference solution
When the level of the reference solution is under the exchange mark or the drawn reference solution is more than one month old, discharge the reference solution in the cylinder and pour new solution.

2-2-6 Handling Reference Solution

1. Handling Reference Solution

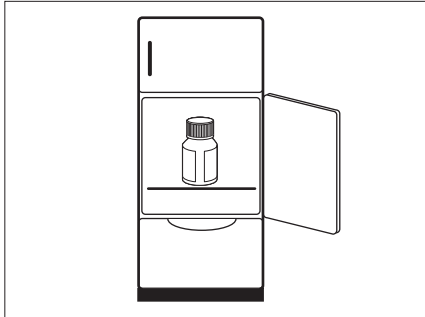

- Store reference solution in a refrigerator (2-8°C). Use it within three months after opening.

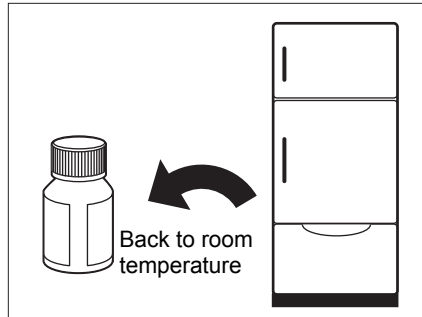

- Remove the solution from the refrigerator and allow it to reach room temperature before measurement.

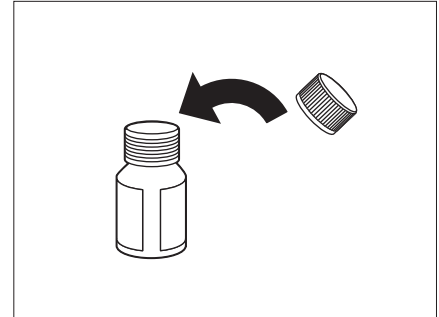

- Always close the lid after use. If the lid is left open, the reference solution may become concentrated and lead to the incorrect measurement results.

2. Handling twin pipette II

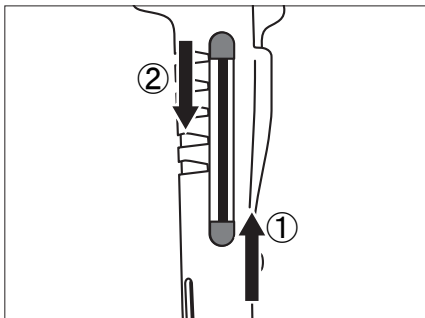

- **Exchange of reference solution**

- ① Soak the tip of the nozzle in the reference solution container, and push up the reference solution suction lever.
- ② After drawing of the reference solution, push the reference solution suction lever down to the bottom and discharge all of it.

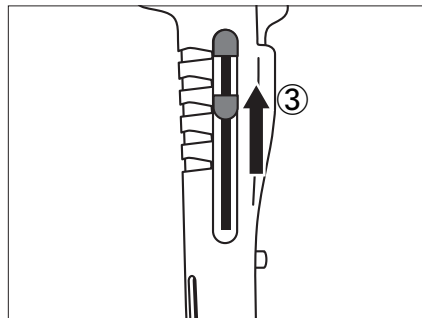

- ③ Draw the reference solution again. After exchanging the reference solutions, lock the reference solution suction lever at the lowest position and the reference solution discharge lever at the highest position. Due to quantity of use, pull the reference solution suction lever up. When the lever at the top, can measure about fifty times.

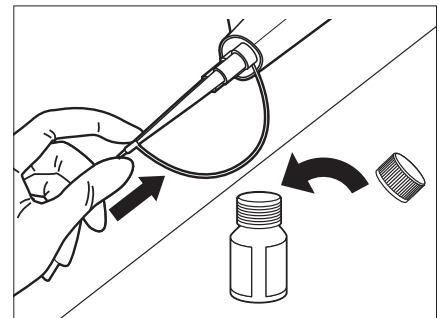

- If it is left open, it will evaporate or become contaminated and correct measurement results will not be obtained.
- After drawing, close the container lid firmly. If it is left open, it will allow evaporation or contamination of the solution, which may lead to incorrect measurement results. Put the nozzle cap back tightly.



Do NOT discharge the reference solution in the container. Improper operations can lead to abnormal measurement results.



If air is found in the cylinder, turn up the tip of the nozzle and push down the drawing lever to evacuate the air.

2-3 Preparation

2-3-1 Preparation

Prepare the necessary items by referring to the following table before normal measurement, and starting magnetic card calibration.

Necessary items	Normal measurement	Magnetic card calibration
Protective glove	○	×
Twin pipette or twin pipette II	○	×
Exclusive E-Plate	○	×
Magnetic card	×	○

IMPORTANT

Allow the exclusive E-Plate to reach room temperature before measurement. Remove the exclusive E-plate from the refrigerator and allow to stand for more than 20 minutes until it reaches room temperature (10-30°C) before measurement. If the exclusive E-plate is not allowed to reach room temperature, correct measurement results cannot be obtained.

2-3-2 Startup

This section explains the operation of analyzer, setting of thermal printer paper and entering data and time.

Turn on the power to activate the plate transfer part to be set at its ready position. Make sure if there are not something else at the plate transfer part.

1. Turn the power

- ▶ The name of the analyzer and its version are displayed and self-diagnosis starts in 5 seconds.
The internal memory is checked on abnormal conditions.
- ▶ If an error or a trouble message appears on the display, something is wrong with the internal memory. Turn off the power and contact your distributor.
- ▶ The internal mechanisms of the analyzer are initialized. Do NOT touch the plate transfer part when it moves. Otherwise, it may damage analyzer or cause injury.

- Turn on the power on the rear of analyzer.
- About 1 minute after (room temperature at 25°C), warm-up is completed and the MAIN MENU is displayed.



SPOTCHEM EL
SE-1520 V1. XXX

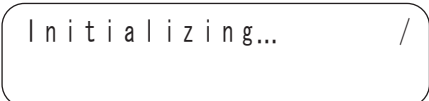

Initializing... /



Warming Up... /

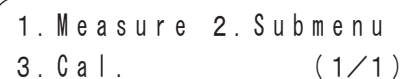

1. Measure 2. Submenu
3. Cal. (1/1)

2-3-3 Checks before Measurement

Before starting measurement, check the twin pipette and thermal printer paper.



Wear protective globes to prevent exposure to pathogenic microbes.



Separate used samples, exclusive E-Plates, tips, and protective gloves from other general waste and dispose of them according to local regulations on biohazardous waste.

► The exclusive E-Plate is sold separately. Please prepare it before measurement.

1. Set the plate tray

- Set the plate tray on the front of analyzer.



Do NOT place things inside of the plate frame. Do NOT bring fingers close to the plate except when the plate is set.

2. Check the twin pipette

- See 2 - 2 - 5 “Handling Twin Pipette and Twin Pipette II.”

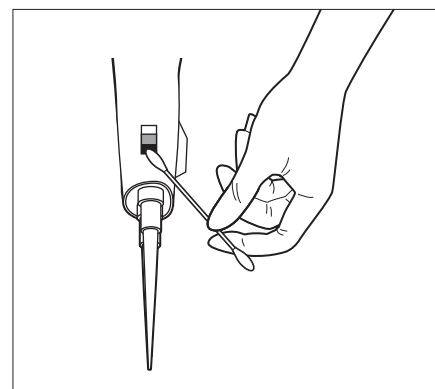

If the reflector on the lower part of the pipette (shiny aluminum board) is stained, wipe the stain to avoid incorrect measurement.

► When you attempt to start measurement without thermal printer paper, a message “No paper” is displayed.

3. Check the thermal printer paper

- When a red line appears on the printer paper, the paper is running out. Replace it with a new roll (see 4-3-1 “Replacement of Thermal Printer Paper”).

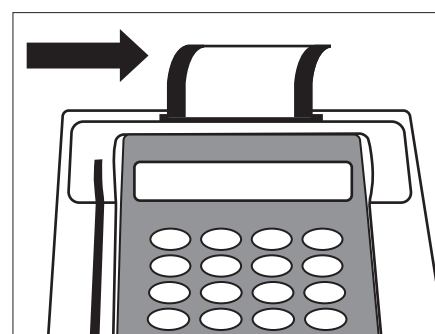

4. Check the Date

- Check the date displayed on the Ready Screen. Correct them, if necessary.
See 3-6 “Built-In Clock Adjustment.”

Standby 2000-04-01
ID(1) INFO(2)

5. Set measurement conditions

- Before starting measurement, set the measurement conditions according to your needs.
“Sample type” can be set on the Lot Check Screen, and “Coefficient” and “Normal value” can be set on the Parameter Menu in the Sub Menu.
See 3-3 “Parameter Menu” for details on “Coefficient” and “Normal value.”

Measurement conditions	Description
Measurement sample type	Set the types of sample to be used consistently.
User coefficient	Measurement results can be multiplied by any coefficient.
Measurement normal value	The range of measurement results can be set.

6. Check the lot information and the sample type setting.

- Press [2] key to check the lot information on the Ready screen.
(See 2-4-1 “Normal Measurement” for details on “lot information”)
- Press [ENTER] key to check the sample type (Whole blood, Serum, Plasma, Urine).



Set the proper sample type. Otherwise, it may lead to incorrect measurement result.

- When [-./] key is pressed, sample types corresponding to the items are displayed in turn.
- Press [ENTER] key to confirm the setting.

Sample Type
[Whole B.]

2-3-4 Preparation of Samples

Prepare samples according to the following procedure (See 2-2-2 “Handling Samples”). The handling procedure of sample may be complemented or modified according to the measurement item in the future. Read the package insert attached to each exclusive E-Plate carefully.



Wear protective gloves in order to prevent microbial infection.

1. Prepare samples

- Prepare samples to measure. Allow refrigerated samples to reach room temperature before use.

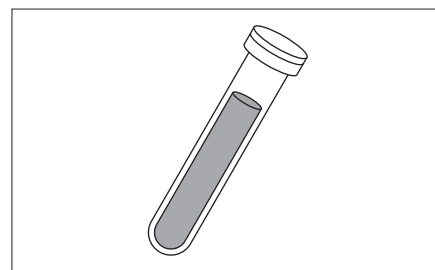

2. Stir samples

- Stir samples by inverting or other mixing methods, without making foam.

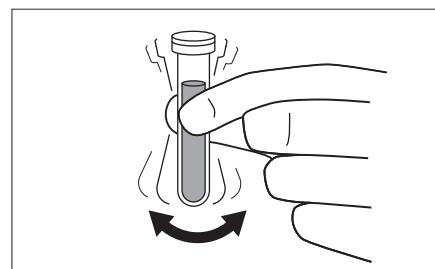

3. Dilute (for urine samples)

- When measuring a urine sample, always use a two-fold dilution made with refine water.

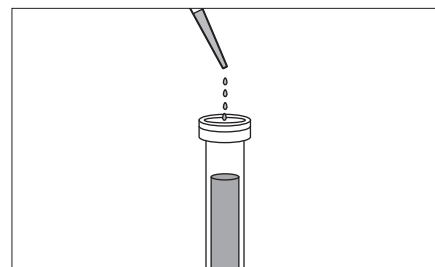

2-3-5 Suction of Reference Solution and Samples

■ When using twin pipette

1. Attach a new tip to the twin pipette

- Attach a tip to the top of the twin pipette.

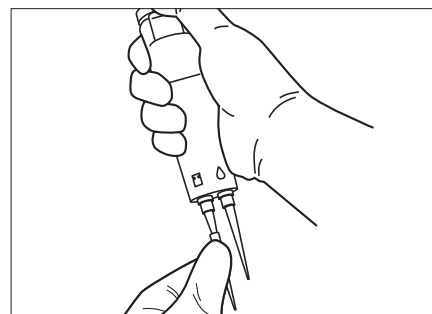

- ① Make sure the pipette tip is firmly attached to the twin pipette.
- ② Exchange the pipette tip in each measurement. Do NOT use it again.

2. Draw up the reference solution

- Press the reference solution button to soak the pipetting tip in the reference solution. Then release the button slowly.

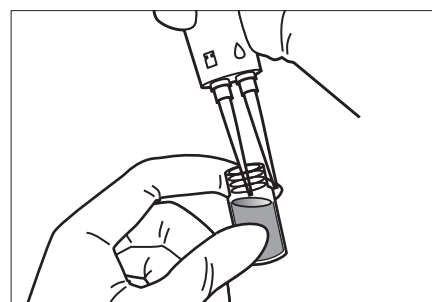

After suction of the reference solution is completed, close the lid of the reference solution container tightly. If it is left open, solution may evaporate or contaminated and may lead to incorrect measurement.

3. Draw up the sample

- Press the sample button to draw up the sample.

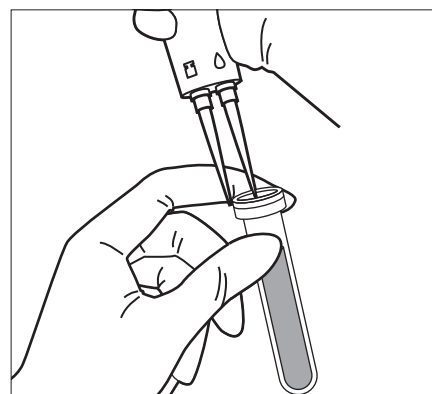

4. Wipe the pipetting tip

- Wipe out excessive reference solution or sample adhered to the pipetting tip with tissue paper, etc.

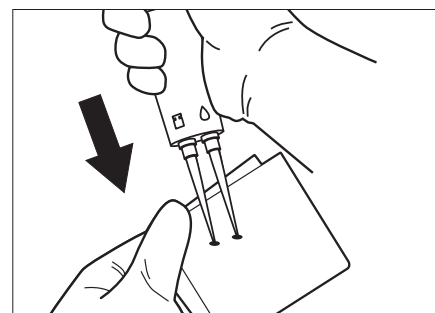

5. Make sure that the level of the reference solution and the sample is approximately same

- If air is mixed in or the suction did not go properly, press the eject button and remove the pipetting tip and put a new tip to perform suction again.

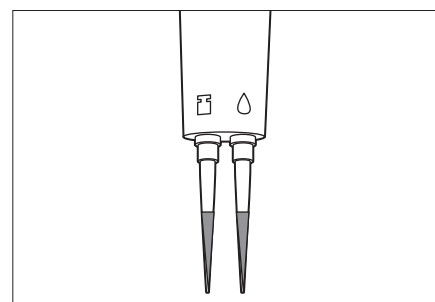

■ When using the twin pipette II

1. Put a pipetting tip on the twin pipette II

- Put a pipetting tip on the sample suction part of the twin pipette II.

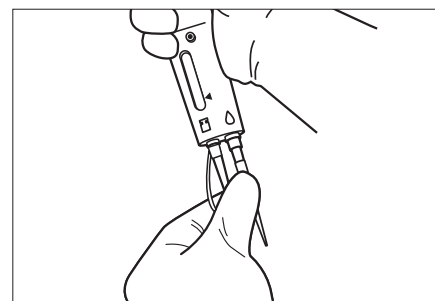

- ① Make sure that the pipetting tip is firmly attached to the twin pipette.
- ② Exchange the pipetting tip for each measurement. Do NOT use it again.

2. Remove the nozzle cap of the reference solution.

- Take off the nozzle cap and place it on the nozzle cap hook of the pipette.
- When the cap is removed, press the reference solution button once to check if the solution is discharged.
- When out of measurement for a long time, press the sample button and discharge the reference solution. (Keep the can concentration of the reference solution by expirating.)
- After taking off the nozzle cap, wipe the nozzle.

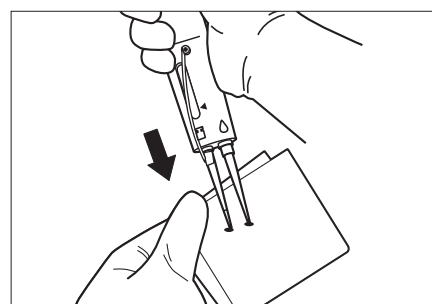
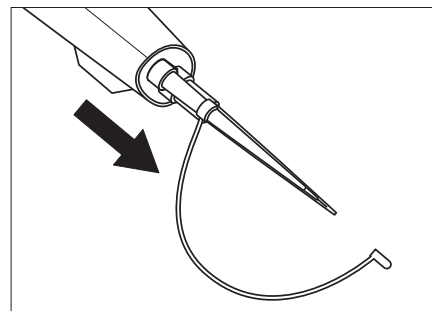

3. Draw up the sample

- Press the sample button to soak the pipetting tip in the sample and release the button slowly.

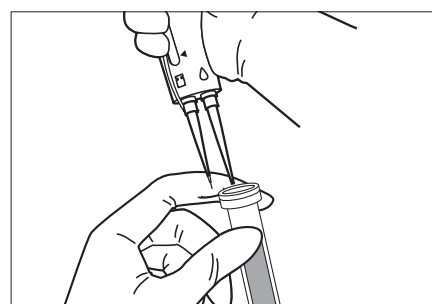

4. Wipe out the pipetting tip

- Wipe out excessive sample adhered around the pipetting tip with tissue paper, etc.

If air is mixed in or the suction did not go properly, press the eject button and remove the pipetting tip and put a new tip to perform suction again.

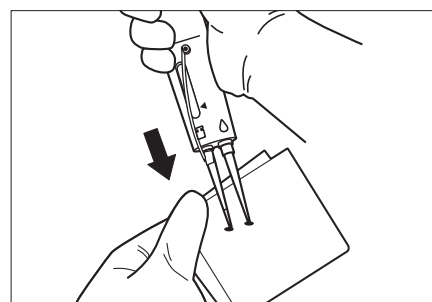

2-4 Measurement

Measurement can be started when the Main Menu is displayed.

When the power of the system is OFF, activate the analyzer by following 2-3-2 “Startup”.

2-4-1 Normal Measurement

This section contains the information on normal measurement for samples.

Before measurement, carefully read “2-3 Preparation” to prepare for measurement. In particular, extreme caution is required for handling samples to prevent accidents.



Wear protective gloves to prevent exposure to pathogenic microbes.

1. Prepare samples

- Prepare samples (see 2-3-4 “Preparation of Samples”).

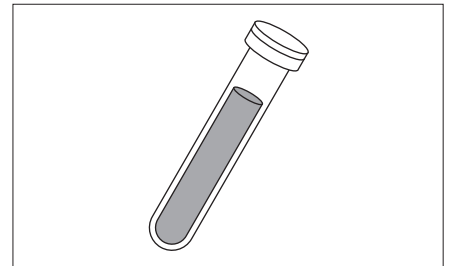

2. Prepare the exclusive E-Plate

- Prepare the required number of the exclusive E-Plates (see 2-2-3 “Handling Exclusive E-Plates”).

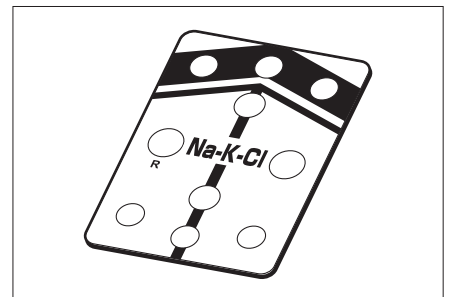

3. Draw up the reference solution and sample

- Draw up the reference solution and sample (see 2-3-5 “Suction of Reference Solution and Samples”).

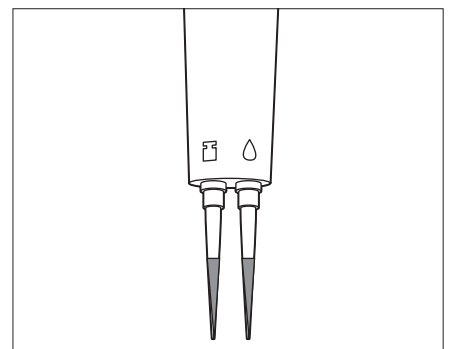

4. Press the Start button

- Press [START] or [1] key.
- Go through the checks before measurement (see 2-3-3 “Checks before Measurement”).

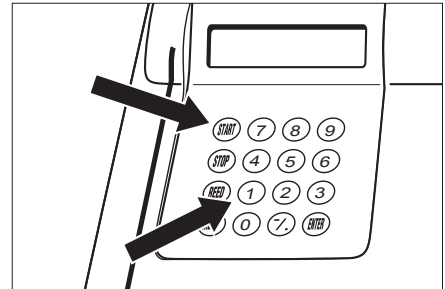

5. Set measurement No. or ID (when necessary)

- ▶ The sequent number from the previous measurement No. is shown as the initial value. Press [ENTER] when you start the measurement with this value. If the power is turned off, the initial value returns to 1.

- Press [1] key on the Ready Screen. Measurement No. Entering Screen appears.

Standby 2000-06-10
ID(1) INFO(2)

No. < >
OK(ENTER)

- Enter the measurement No. Up to 4-digit number is available to set.
- Press [ENTER].

- ▶ The previously entered ID is displayed as the initial value. If you want to continue measurement with the sequent ID, press [ENTER]. However, once you go back to the Main Menu, the previous ID is deleted.

- The entered measurement No. is stored and the ID Entering Screen is displayed.

ID< >
OK(ENTER)

- ▶ Use numeric keys and [-./] keys to enter IDs. The following 12 symbols can be entered with [0] key.
* ? # . . . ; ' - + / %

- Enter ID. ID can be entered using alphanumeric keys and hyphens (up to 13 digits).

- ▶ Press [-./] key to move the cursor. Press [-./] key while pressing [MENU] key to delete the last character. Press [START] key to return to the first displayed ID.

- When a barcode reader is used, the barcode is read.

- ▶ When the optional barcode reader is in use, ID entry with key is not necessary. The read barcodes are allocated as IDs of sample.

- When the barcode reader is used, a message "Barcode reader is available" is displayed.

- The entered ID is displayed.
- Press [ENTER].

ID<***** >
OK(ENTER)

- The entered ID is stored and the screen returns to the Ready Screen.



If not enter measurement No. and ID, to "7. Set the E-Plate on the table". Normally measurement No. is allocated automatically. ID is not entered in the such way.

6. Set the sample type (when necessary)

- See procedure 6 of 2-3-3 "Checks before Measurement" to set the sample type.

7. Set the E-Plate on the table

- Set the E-Plate onto the proper location of the analyzer.

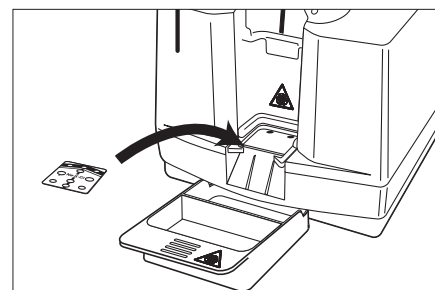

8. Make sure the lot number

- When E-Plate is set, either following [1] or [2] is displayed.
- When this screen is displayed, check if used lot number for E-Plate is same as $\Delta\Delta\Delta\Delta\Delta$ on the display.

[1] Apply sample
[Whole B.] $\Delta\Delta\Delta\Delta\Delta$



If the lot number is not same, a correct data can not be obtained. In this case, calibrate by a magnetic card.

- When this screen is displayed, proceed to the next stage without checking lot number.

[2] Apply sample
[Whole B.] No. *****

9. Start pipetting

- Make sure that a message “Apply sample” is displayed.
- Insert the twin pipette or the twin pipette II correctly.
- Make sure that a message “Apply sample” is displayed again.
- The tip of the pipetting nozzle is positioned on the center of the pipetting part on the plate.
- Press the reference solution button and the sample button simultaneously to pipette. Press the button fully, especially the twin pipette II.
- Press the button slowly and fully. Then stay for approximately one second.
- Pull out the pipette from the pipetteguide within 5 seconds keep pressing the button.
- Press the eject button to remove the pipetting tip. When the twin pipetting II is used, wipe out excessive reference solution adhered to the nozzle with tissue paper, etc. and put the nozzle cap on.

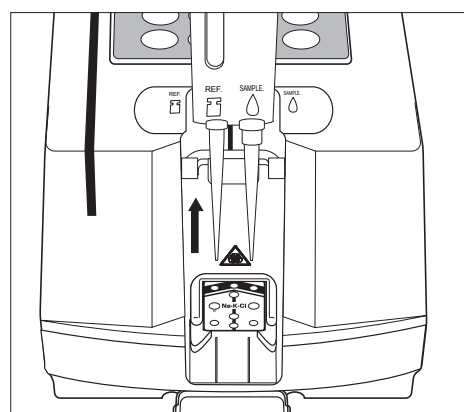
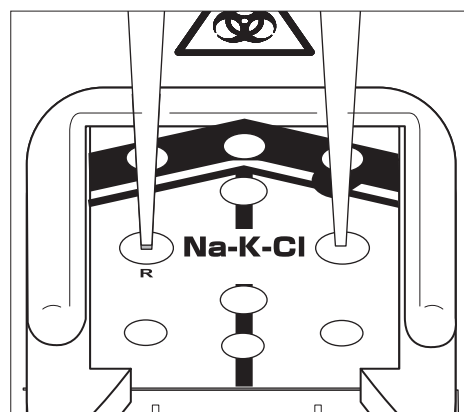
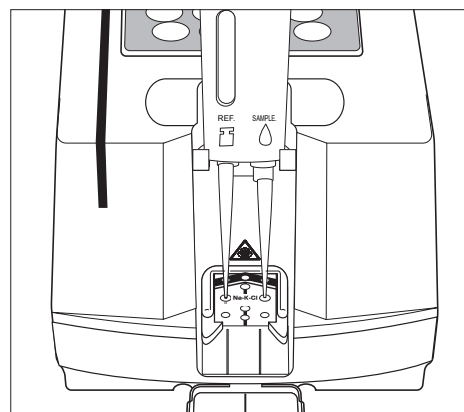

10. Measure

- When the twin pipette is pulled out, the plate transfer part automatically moves to the measurement part and electric potential is measured. About one minute later, the measurement result is printed. During this operation, the upper right corner of the display shows the remaining time to the end of the measurement.

11. End the measurement

- When the measurement is finished, a buzzer notifies that the measurement is completed.
- At the same time, the measurement result is printed out.



12. End measurement for the day

- When finishing all measurement for the day, perform daily maintenance (see 4-2 “Daily Maintenance”).

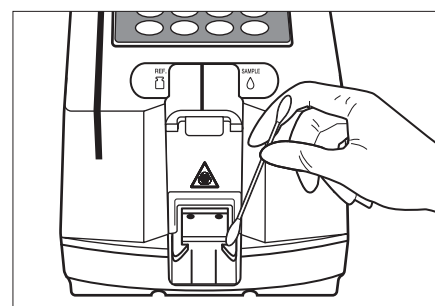

Separate used samples, E-Plate, and cleaning equipment from general waste and dispose of them according to local regulations on biohazardous waste.

2-5 Calibration

2-5-1 Overview

Calibration is necessary for maintaining measurement accuracy. By performing calibration, the problems caused by differences among lots are solved and measurement accuracy is maintained. Basically, calibration is performed for each exclusive plate type using exclusive calibrators. However, it will take a long time to perform calibration for all exclusive plates. To reduce the time and trouble, this system performs calibration by reading magnetic cards recording lot information of each exclusive plate. This method is called “Magnetic Card Calibration.” Using this magnetic card calibration method, calibration is performed by inserting the magnetic card attached to the exclusive plate into the magnetic card reader.

2-5-2 Magnetic Card Calibration

Differences among lots of the exclusive plate are automatically corrected by inserting the magnetic card attached to the exclusive plate into the magnetic card reader.

IMPORTANT

If the measurement is performed when the magnetic card calibration is not performed correctly, errors occur and measurement may not start. In this case, be sure to perform “Magnetic Card Calibration.”

1. Check the recorded information

- Press [3] on the Main Menu.
The Calibration Menu is displayed.
- Press [2].
Lot information of all items recorded in the system is printed.
When the printing is completed, you return to the Calibration Menu.

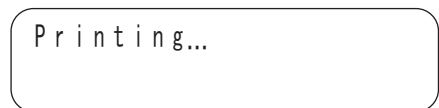
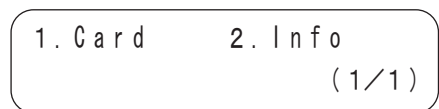

2. Insert magnetic cards

- Press [1] key. the Magnetic Card Entry Screen is displayed.
- Insert the stripe of item card or lot card in the magnetic-card reader. Slide the card as shown as the right.

1. CARD 2. Info
(1/1)

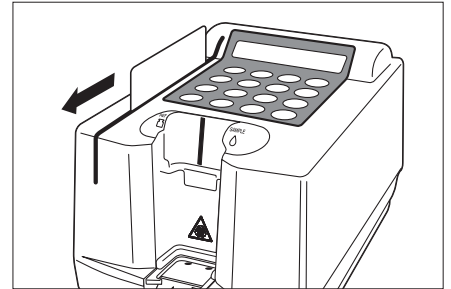

- Insert the same stripe in the card reader again. When the same stripe is inserted twice, the stripe number is displayed.

Insert a Card.
The Same stripe 1234

- Insert the remaining stripes in the card reader twice.
- When all the stripes are inserted, the test items (item card) or the test items and lot number (lot card) are displayed.
- About 2 seconds after, the Magnetic Card Entry Screen is displayed. That's all for calibration by magnetic card.

Insert a Card.
Another Stripe 1234

Insert a Card.
(STOP)

3. End calibration

- When calibration is not performed consecutively, press [STOP] key to return to the MAIN MENU

1. Measure 2. Submenu
3. Cal. (1/1)

2-6 Measurement Result

2-6-1 Printing the Normal Measurement Results

(1) Normal printing

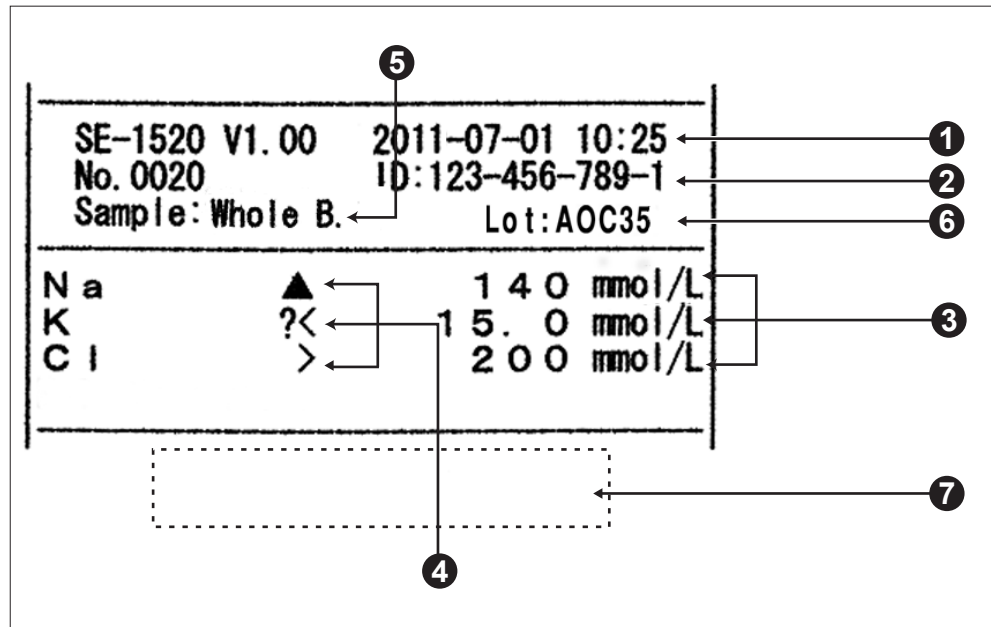

1. **Measurement date** The format of the measurement date is "date format".
2. **ID** When there is no ID, it becomes blank. ("ID:" is not printed.)
3. **Concentration value** When the measurement result is out of the measurement range, the following is printed.
 When the measurement result is over the range: the upper limit of the measurement range are printed.
 When the measurement result is under the range: the lower limit of the measurement range are printed.
4. **Error mark** Stability error "?"
 Error of the lower limit of the measurement range "<"
 Error of the upper limit of the measurement range ">"
 Error of the lower limit of the normal measurement range "▼"
 Error of the upper limit of the normal measurement range "▲".
 * All fields for concentration values are printed with "-" in the event of no solution errors.
5. **Sample type** Printed in accordance with the selected language.
 Whole blood measurement: Whole blood
 Plasma measurement: Plasma
 Serum measurement: Serum
 Urine measurement: Urine
6. The lot information for used E-Plate is printed out.
7. **Error printing** When error message is printed at the end of measurement result, see 5-1 "Error Messages".

(2) Survey mode printing

SE-1520 V1.00		2000-07-01 10:25	
No. 0020		ID:123-456-789-1	
Sample: Whole B.		Lot:AOC35	
Na	140	mmol/L	①
	135	mmol/L	②
Temperature conversion .. [----]			
	Kt=	1.000	③
Unit conversion [mmol/L]			
	Ku=	1.000	④
Correlation correction			
	Acor=	1.037 Bcor=	0.000 ⑤
K	15.0	mmol/L	
	14.3	mmol/L	
Temperature conversion .. [----]			
	Kt=	1.000	
Unit conversion [mmol/L]			
	Ku=	1.000	
Correlation correction			
	Acor=	1.000 Bcor=	0.000
Cl	200	mmol/L	
	185	mmol/L	
Temperature conversion .. [----]			
	Kt=	1.000	
Unit conversion [mmol/L]			
	Ku=	1.000	
Correlation correction			
	Acor=	1.000 Bcor=	0.000

Basically the survey mode printing is performed in the same way as normal printing. However, the following is printed in addition to the measurement value of each channel.

1. Printing of measurement values (concentration value, various marks) is the same as in normal printing.
2. Concentration values (before correction by coefficient of correlation correction) are printed.
3. **Temperature conversion coefficient:** Measurement value = Kt × Measurement value before conversion.
4. **Unit conversion coefficient:** Measurement value = Ku × measurement value before conversion.
5. **Correlation correction coefficient:** Measurement value = Acor × Measurement value before correction + Bcor

Chapter 3

Sub Menu

The SE-1520 has a main menu and five sub menus.
Sub menus are classified by setting items.
Chapter 3 explains how to perform Sub Menu settings.

3-1 Overview

3-1-1 Contents of Each Menu

3-2 Measurement Results Menu

- 3-2-1 Printing Measurement Results
- 3-2-2 Transmitting Measurement Results
- 3-2-3 Deleting Measurement Results
- 3-2-4 Wildcards

3-3 Parameter Menu

- 3-3-1 Printing Parameters
- 3-3-2 Entering Parameters
- 3-3-3 Initializing Parameters

3-4 Maintenance Menu

- 3-4-1 Cleaning the Probe
- 3-4-2 Cleaning the Table
- 3-4-3 Check Measurement

3-5 Mode Menu

- 3-5-1 Survey Mode

3-6 Built-in Clock Adjustment



3-1 Overview

3-1-1 Contents of Each Menu

- ▶ If [STOP] key is pressed during operation, the setting is cancelled and the previous screen is restored.
- ▶ If [START] key is pressed during any MENU operation, the MAIN MENU is restored.

■ MAIN MENU

When warm-up is completed after turning on the power, MAIN MENU is displayed. Press [1] key on MAIN MENU to go to Measurement; [2] key to SUB MENU; [3] key to Calibration.

■ SUB MENU

The SUB MENU has 2 pages. Press [MENU] key or the [hyphen (-)] key to switch the SUB MENU pages alternately between SUB MENU 1/2 and SUB MENU 2/2. The SUB MENU has several functions arranged in layered structure.

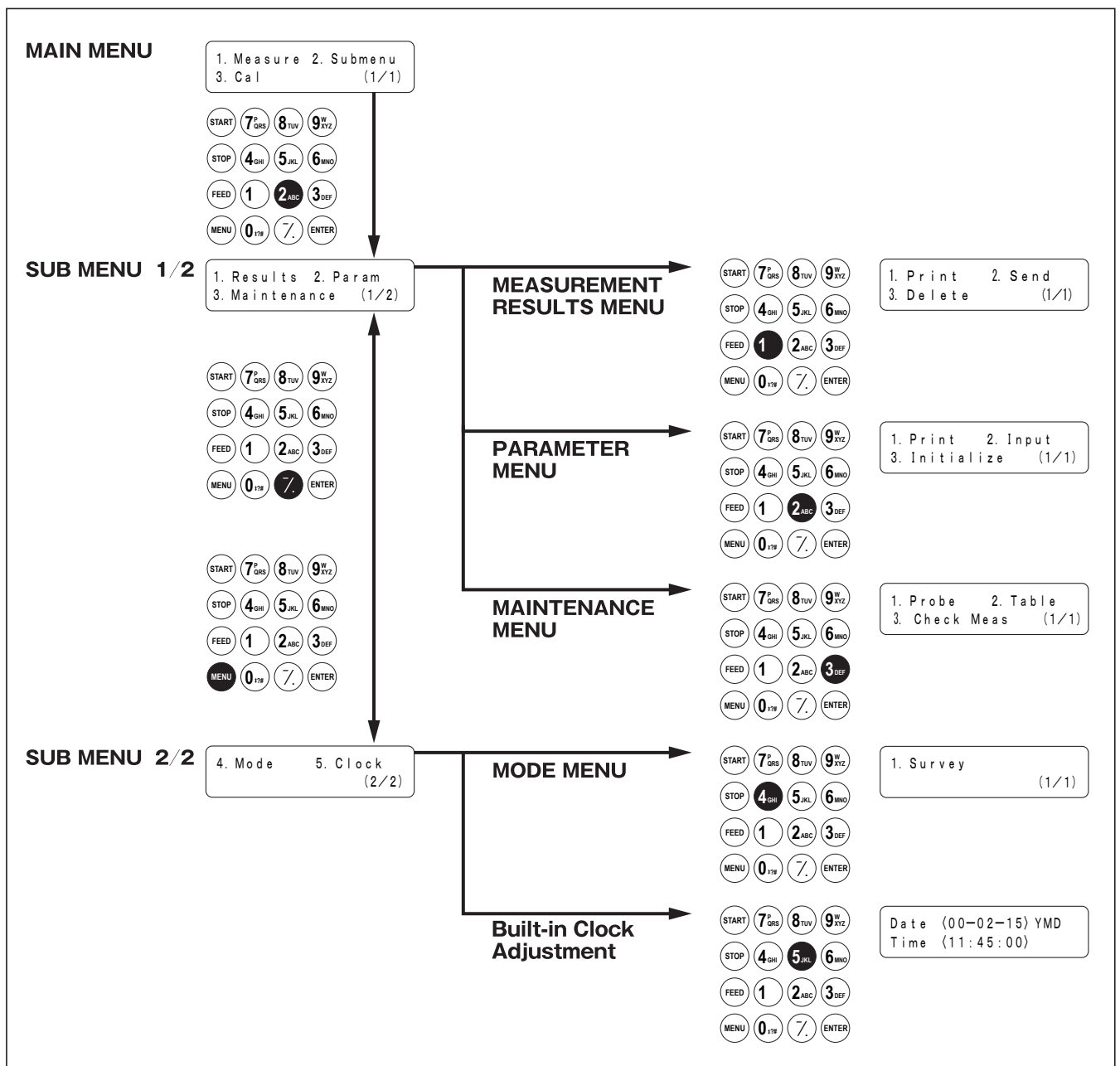

Measurement Results Menu

Item	Description	Reference Item
1. Print Printing measurement results	Prints measurement results stored in memory. Search by date and ID is available.	3-2-1
2. Transmit Transmitting measurement results	Transmits measurement results stored in memory to an external device.	3-2-2
3. Delete Deleting measurement results	Deletes all the measurement results stored in memory.	3-2-3

Parameter Menu

Item	Description	Reference Item	
1. Print Printing parameters	Prints out the present parameter settings.	3-3-1	
2. Enter Entering parameters	Coefficient of correlation correction	3-3-2	
	Normal value range		Enter coefficient values for a and b of the regression equation $Y=aX+b$.
	Correction temperature		Enter upper and lower limit values.
3. Initialize Initializing parameters	Initialize the present parameter settings.	3-3-3	

Maintenance Menu

Item	Description	Reference Item
1. Probe Clean the probe pin	Clean the probe pin	3-4-1
2. Table Clean the table	Clean the table.	3-4-2
3. Check Measurement	Measure with the check plate	3-4-3

Mode Menu

Item	Description	Reference Item
1. Survey Survey Mode	Set ON or OFF for the Survey Mode.	3-5-1

Built-in Clock Adjustment

Item	Description	Reference Item
Built-in Clock Adjustment	Set the date and time.	3-6

3-2 Measurement Results Menu

3-2-1 Printing Measurement Results

- ▶ If [STOP] key is pressed during operation, the previous screen is restored.
- ▶ Measurement results are printed out in a new-to-old sequence.

Measurement results (up to 50 samples) stored in memory can be printed out. The printing type can be chosen from the following.

- 1. LATEST : The latest measurement result (one sample).**
- 2. ALL: All the measurement results (up to 50 samples) stored in memory.**
- 3. SEARCH : The measurement results searched by the date and/ or ID.**

1. Display setting screen

- Press [2] key on the MAIN MENU.
The SUB MENU 1/2 is displayed.
- Press [1] key.
The MEASUREMENT RESULTS MENU is displayed.

```
1. Results   2. Param
3. Maintenance (1/2)
```

```
1. Print     2. Send
3. Delete    (1/1)
```

2. Select measurement results to print

- Press [1] key.
The Select Results screen is displayed.
- Select the measurement results to print by using the numeric keys.
 1. LATEST : the latest measurement result (1 sample)
 2. ALL : all the measurement results
 3. SEARCH : search by date and ID

```
1. Latest   2. All
3. Search   (1/1)
```

- **When [LATEST] or [ALL] is selected.**
Printing starts immediately. After printing is completed, the SELECT Results screen is restored.
- **When [SEARCH] is selected.**
The display proceeds to "3. Select samples to print".

```
No data matched
OK(ENTER)
```

- ▶ If the measurement result you selected is not found in the data, "No data matched" is displayed as shown on right. Press [ENTER] key to return to the Select Results screen.

- ▶ If the range of measurement dates (the dates of starting and finishing measurements) is not specified, press [ENTER] key to go on to the next setting screen.
- ▶ Be sure to enter correct dates to avoid inconsistency.
- ▶ The 2-digit number of the "year" section of the date indicates the last 2 digits of year and is interpreted as follows:
00 - 89→2000 - 2089
90 - 99→1990 - 1999

- ▶ See 3-2-4 "Wildcards" for information on wildcards.

- ▶ To stop printing, press [STOP] key. Printing stops and the Select Results screen is restored.

3. Select samples to print

- Enter the dates of starting and finishing measurement by moving the cursor with the [hyphen (-)] key.

```
Date  <99-12-15>YMD
      to <00-02-05>
```

- Press [ENTER] key.
The Enter ID screen is displayed.

```
ID<█>
```

- Enter an ID search pattern for the sample(s) to print by using numbers, alphabets and signs up to 13 characters in all.

```
ID <99-12-25-ABCD>
```

- The handy barcode reader or wildcards such as "?" and "*" can be used.

- Press [ENTER] key.
The Selected measurement results are printed out and the progress status of printing is displayed.

```
Printing... ( 4 / 15)
              Stop (STOP)
```

- When the printing is completed, the Select Results screen is restored.

- If the measurement result selected is not found in the data, "No data matched" is displayed as shown on the right.

```
1. Print      2. Send
3. Delete      (1/1)
```

- Press [ENTER] key to return to the Select Results screen.

```
No data matched
              OK (ENTER)
```

4. End Printing

- Press [STOP] key to return to the MAIN MENU.

```
1. Measure   2. Submenu
3. Cal.      (1/1)
```

3-2-2 Transmitting Measurement Results

- ▶ If [STOP] key is pressed during operation, the previous screen is restored.
- ▶ Measurement results are transmitted in sequence of date from the latest result.

Measurement results (up to 50 samples) stored in memory can be transmitted.

The transmitting type can be chosen from the following.

- 1. LATEST : The latest measurement result (one sample).**
- 2. ALL: All the measurement results (up to 50 samples) stored in memory.**
- 3. SEARCH : The measurement results searched by the date and/ or ID.**

1. Display setting screen

- Press [2] key on the MAIN MENU.
The SUB MENU 1/2 is displayed.

```
1. Results    2. Param
3. Maintenance (1/2)
```

- Press [1] key.
The MEASUREMENT RESULTS MENU is displayed.

```
1. Print      2. Send
3. Delete    (1/1)
```

2. Select measurement results to transmit

- Press [2] key.
The Select Results screen is displayed.

```
1. Latest    2. All
3. Search    (1/1)
```

- Select the measurement results to transmit by using numeric keys.
 1. LATEST : the latest measurement result (1 sample)
 2. ALL : all the measurement results
 3. SEARCH : search by date and ID

- **When [LATEST] or [ALL] is selected**

Transmission starts immediately. After transmission is completed, the Select Results screen is restored.

- **When [SEARCH] is selected**

The display proceeds to "3. Select sample to transmit".

```
No data matched
OK(ENTER)
```

- ▶ If the measurement result selected is not found in the data, "No data matched" is displayed as shown on the right. Press [ENTER] key to return to the Select Results screen.

▶ If the range of measurement dates (the dates of starting and finishing measurements) is not specified, press [ENTER] key to go on to the next setting screen.

▶ Be sure to enter correct dates to avoid inconsistency.

▶ The 2-digit number of the "year" section of the date indicates the last 2 digits of year and is interpreted as follows:
00 - 89 → 2000 - 2089
90 - 99 → 1990 - 1999

▶ See "3-2-4 Wildcards" for information about wildcards.

▶ To stop transmission, press [STOP] key. Transmission stops and the Select Results screen is restored.

3. Select samples to transmit

- Enter the dates of starting and finishing measurements by moving the cursor with [hyphen (-)] key.

Date <99-12-15>YMD
to <00-02-05>

- Press [ENTER] key.
The Enter ID screen is displayed.

ID <█ >

- Enter an ID search pattern for the sample(s) to transmit by using numbers, alphabets, and symbols up to 13 characters in all.
The handy bar code reader or wildcards such as "?" and "*" can be entered as well.

ID <99-12-25-ABCD>

- Press [ENTER] key.
The selected measurement results are transmitted and the progress status of transmission is displayed.

Sending... (4 / 15)
Stop (STOP)

- When transmission is completed, the Select Results screen is restored.

1. Print 2. Send
3. Delete (1/1)

- If the measurement result selected is not found in the data, "No data matched" is displayed as shown on the right.
Press [ENTER] key to return to the Select Results screen.

No data matched
OK (ENTER)

4. End transmission

- Press [STOP] key to return to the MAIN MENU.

1. Measure 2. Submenu
3. Cal. (1/1)

3-2-3 Deleting Measurement Results

All the measurement results stored in memory can be deleted.

1. Display setting screen

- Press [2] key on the MAIN MENU.
The SUB MENU 1/2 is displayed.

```
1. Results   2. Param
3. Maintenance (1/2)
```

- Press [1] key.
The MEASUREMENT RESULTS MENU is displayed.

```
1. Print     2. Send
3. Delete   (1/1)
```

2. Delete measurement results

- Press [3] key.
The Enter Password screen is displayed.
Enter password 99 and " * * " is displayed on the screen.

```
Password < ** >
          Cancel (STOP)
```

- The Confirmation screen is displayed.

```
Delete?
Yes (START) No (STOP)
```

- Select [START] or [STOP] key.

When deleting→

If [START] key is pressed, the measurement results are deleted and the MEASUREMENT RESULTS MENU is restored.

When not deleting→

If [STOP] key is pressed, deletion is canceled and the MEASUREMENT RESULTS MENU is restored.

```
1. Results   2. Param
3. Maintenance (1/2)
```

3. End Deletion

- Press [STOP] key to return to the MAIN MENU.

```
1. Measure   2. Submenu
3. Cal.     (1/1)
```

3-2-4 Wildcards

■ wildcards

Wildcards can be used for ID search. Wildcards are two special characters, "?" and " * ", indicating a single or any number of characters.

- "?" indicates a single character.
- " * " indicates any number (including zero) of characters.

For instance, if "?????" is entered, 4-character IDs are searched. If "A * " is entered, IDs starting with "A" are searched. The following table shows details.

	Search pattern	Meaning
Example1	? ? ? ? M	5-character ID ending with "M"
Example2	A B ? Y Z	5-character ID starting with "AB" and ending with "YZ"
Example3	A B * Y Z	ID starting with "AB" and ending with "YZ"
Example4	* P Q R *	ID including "PQR"
Example5	N ? ? ? *	ID of 4 characters or more starting with "N"

This function is upper/lower case sensitive.

"?" or " * " itself cannot be searched for. (e.g,) if=? * "is entered to search IDs starting, with "?", the attempt will fail.

More than four asterisks (*)cannot be entered as a search pattern.

SE-1520 V1.021 2000-11-10 10:24	
Parameter	
Na	← ①
Item No.	X ← ②
Correlation correction	← ③
Serum Acor= 1.000 Bcor= 0.000	← ④
Plasma Acor= 1.000 Bcor= 0.000	← ⑤
Whole Acor= 1.000 Bcor= 0.000	← ⑥
Urine Acor= 1.000 Bcor= 0.000	← ⑦
Range	← ⑧
Limit [mmol/L]	← ⑨
Blood 50 - 250	← ⑩
Urine 10 - 350	← ⑪
Normal [mmol/L]	← ⑫
Blood 50 - 250	← ⑬
Urine 10 - 350	← ⑭
Temperature conversion	----- ← ⑮

1. Measurement item name
2. Measurement item No.
3. Sample type Correction coefficient
4. Serum correction coefficient
5. Plasma correction coefficient
6. Whole blood correction coefficient
7. Urine correction coefficient
8. Measurement range
9. Measurement value range [Unit]
10. Blood range
11. Urine range
12. Normal value range [Unit]
13. Blood range
14. Urine range
15. Temperature compensation value (25°C: "25°C",30°C: "30°C",No correction: "-----")

3-3-2 Entering Parameters

- ▶ If you press [STOP] key is pressed during entry, the entry is cancelled and the cursor returns to the previous "[]" or "<>".
- ▶ If there is no need to change the previous setting, press [ENTER] key to go on to next "[]" or "<>".

Parameters for "Coefficient of correlation correction", "Normal value range" and "Correction Temperature" can be set.

■ Coefficient of correlation correction

This function allows the results obtained by this device to match the results by another measurement method (reference method). Apply the regression equation $Y = aX + b$, (X : the result measured by the SE-1520, Y : the result obtained by the reference method.) Enter coefficient values for a and b. For obtaining the coefficients of correlation correction for a and b, contact your distributor.

■ Normal value range

Data out of the normal value range are marked with ▲ or ▼, when printed.

■ Correction Temperature

Measurement is always performed at 32°C as the measurement temperature in this analyzer. Converts the measurement results to the ones measured at 25°C, 30°C, or 32°C and outputs the converted results. However only the enzyme items can be converted.

1. Display setting screen

- Press [2] key on the MAIN MENU.
The SUB MENU 1/2 is displayed.

```
1. Measure  2. Submenu
3. Cal.      (1/1)
```

- Press [2] key.
The Parameter Menu is displayed.

```
1. Results  2. Param
3. Maintenance (1/2)
```

- Press [2] key and the Enter
Password screen is displayed.
Enter password "99".
" * * " is displayed

```
1. Print    2. Input
3. Initialize (1/1)
```

```
Password < ** >
                Cancel (STOP)
```

- Press [ENTER] key.
The Select Item screen is displayed.

```
[ No. 01 : Na      ]
( 1 / 11 )
```

2. Select item

- Press [hyphen(-)] key to select measurement item for parameter setting.
- Press [ENTER] key.
The Coefficient Factor Setting screen is displayed.

```
[ No. 02 : K      ]
( 2 / 11 )
```

```
Serum  a < █  1.000 >
S-02   b <    0.000 >
```

- ▶ Besides the [hyphen (-)] key, [0], [2], [4], [6], and [8] keys can be used to select item .
[0]→Item displayed first
[2]→Last item
[4]→Item before the current item
[6]→Next item of the current item
[8]→The first item

- ▶ Enter minus signs and decimal points by using the "-/." key. To enter a minus sign, press [-/.] before pressing any numeric keys. A decimal point can be entered. Press [-/.] key after any numeric key is pressed.

e.g.) To enter "-12

Press [-/.] [1] [2]

e.g.) To enter "3.4"

Press [3] [-/.] [4]

e.g.) To enter ".5"

Press [0] [-/.] [5]. If only [-/.] [5] is pressed, -.5 is entered.

- ▶ If the wrong key is pressed, press [MENU] key and [-/.] simultaneously to delete the last entered character.

- ▶ If [START] key is pressed, the initially displayed value is restored.

3. Set coefficient factors

- Enter the coefficient factor "A" by using the numeric keys. Any number from 0 to 10000 can be entered.
- Press [ENTER] key and the cursor moves to the entry position for "B". Enter a coefficient factor "B" and press [ENTER]. Any number from -10000 to 10000 can be entered. Press [ENTER] key and the next setting screen is displayed. After coefficients for whole blood, serum, plasma and urine are entered, the Normal Value Range Setting screen is displayed.

```
Serum  a < 1.000 >
S-02   b < 0.000 >
```

```
Serum  a < 1.000 >
S-02   b < 0.000 >
```

4. Normal value ranges

- Enter the lower value of the normal value range by using the numeric keys.
- Press [ENTER] key and the cursor moves to the entry position for the highest limit.
- Enter the upper value using the numeric keys and press [ENTER] key. Then the next setting screen is displayed. After the normal value ranges for blood and urine are entered, Correction Temperature Setting Screen is displayed.

```
Blood NORM L < 1.000 >
S-02          U < 15.00 >
```

```
Blood NORM L < 1.000 >
S-02          U < 15.00 >
```

5. Set the correction temperature

- ▶ Only the enzyme items can be converted at the selected correction temperature.

- Press [-] key to select Correction Temperature.
- Press [ENTER] key. The Entry Check Screen is displayed.

```
Temperature [----]
S-02
```

```
Save?
Yes (START) No (STOP)
```

6. Set all the parameters

- Press [START] or [STOP] key.
When [START] key is pressed, the parameter settings are stored and the Select Item screen is restored.
- When [STOP] key is pressed, the settings are canceled and the Select Item Screen in the procedure 1 is restored.

Writing... /

[No. 02 : K]
(2 / 11)

7. End setting

- If the setting is finished, press [STOP] key three times to return to the MAIN MENU.

1. Measure 2. Submenu
3. Cal. (1/1)

3-3-3 Initializing Parameters

Parameter settings can be initialized to the factory setting. See "Factory set parameter values" for the details.

1. Display setting screen.

- Press [2] key on the MAIN MENU.
The SUB MENU 1/2 is displayed.
- Press [2] key.
"Parameter Menu" is displayed.
- Press [3] key.
"Password Entering screen" is displayed. Enter password "99".
" * * " is displayed.
Press [ENTER] key.
- The Select Item screen is displayed.

1. Results 2. Param
3. Maintenance (1/2)

1. Print 2. Input
3. Initialize (1/1)

Password < ** >
Cancel (STOP)

[No. 01 : Na]
(1 / 11)

- ▶ Besides [hyphen (-)] key can be used to select items, [0], [2], [4], [6], and [8] keys can be used to select item.
 - [0]→Item displayed first
 - [2]→Last item
 - [4]→Item before the current item
 - [6]→Next item of the current item
 - [8]→The first item

2. Initialize parameters

- Press [hyphen (-)] key to select measurement item to initialize.
- Press [ENTER] key.
The Confirmation screen is displayed.
- Select [START] key or [STOP] key.
When performing initialization→
If [START] key is pressed, the parameters are initialized and the Select Item screen is restored.
When not performing initialization→
When [STOP] key is pressed, the Initialization is canceled and the Select Item screen is restored.

[No . 0 3 : C I]
(3 / 1 1)

I n i t i a l i z e ?
Y e s (S T A R T) N o (S T O P)

W r i t i n g . . .

3. End Initialization

- When the initialization is finished, press [STOP] key to return to the MAIN MENU.

1 . M e a s u r e 2 . S u b m e n u
3 . G a l . (1 / 1)

- ▶ Present parameter settings can be checked, if it is necessary see 3-3-1 "Printing Parameters" for details.

■ Factory set parameter values

The following table shows the conditions of the factory setting.
Refer to this table to set each condition.

Range or Selection	Factory setting	
Coefficient of correlation correction	a : 0 - 10000	a : 1.0
	b : -10000 - 10000	b : 0.0
Normal value range	L : 0 - 10000	Measurement range
	H : 0 - 10000	
Correction temperature	「25°C」 「30°C」	「-----」
	「-----」 (No correction)	

3-4 Maintenance Menu

3-4-1 Cleaning the Probe

- When [1. Probe] is selected, the block inside the analyzer moves. Open the maintenance cover of the bottom to clean the probe pin.
See "4-3-2 Cleaning the Probe" for the details.

3-4-2 Cleaning the Table

- When [2. Table] is selected, the plate transfer part is drawn back inside the system.
When the plate transfer part is drawn back, the plate setting place and table of the system can be cleaned.
See "4-2-2 Cleaning the Plate Transfer Part" for the details.

3-4-3 Check Measurement

- When [3. Check Meas] is selected, check measurements with check plates can be performed.
See "4-3-2 Cleaning the Probe" for the details.

3-5-1 Survey Mode

► The Survey Mode is canceled automatically if the power is turned off.

Switch to the Survey Mode. When measurement is done in the Survey Mode, raw data can be printed out besides ordinary measurement results (see 2-6 "Measurement Result" for details of printouts).

1. Display setting screen

- Press [2] key on the MAIN MENU.
The SUB MENU 1/2 is displayed.

1. Results 2. Param
3. Maintenance (1/2)

- Press [MENU] key or [hyphen (-)] key.
The SUB MENU 2/2 is displayed.

4. Mode 5. Clock
(2/2)

- Press [4] key.
The Mode Menu is displayed.

1. Survey
(1/1)

- Press [1] key.
The Survey Mode Setting screen is displayed.

Survey [ON]

2. Switch to the Survey Mode

- Press [hyphen (-)] key. Select [ON] or [OFF] by using [hyphen (-)] key.
- Press [ENTER] key.

Survey [ON]

3. End Survey Mode

- When the setting is finished, press [STOP] key to return to the MAIN MENU.

1. Measure 2. Submenu
3. Cal. (1/1)

3-6 Built-in Clock Adjustment

Set the date and time of the built-in clock. Once you set the date and time, resetting is not necessary, however, some adjustment may be required in a long period of use.

1. Display setting screen

- Press [2] key on the MAIN MENU.
The SUB MENU 1/2 is displayed.

```
1. Results  2. Param
3. Maintenance (1/2)
```

- Press [MENU] key or [hyphen (-)] key. The SUB MENU 2/2 is displayed.

```
4. Mode      5. Clock
                (2/2)
```

- Press the [5] key.
"Password Entering screen" is displayed. Enter password "99", " * * " is displayed.

```
Password < * * >
                Cancel (STOP)
```

- Press [ENTER] key.
The Clock Adjustment screen is displayed.

```
Date < 00-02-15 > YMD
Time < 11:45:00 >
```

2. Set the date and time

- Enter the present date by using [hyphen (-)] key.
- Press [ENTER] key. The cursor moves to the time entry position.
- Enter the present time by using [hyphen (-)] key.
- Press [ENTER] key.
The set date and time is stored and the SUB MENU 2/2 is restored.

```
Date < 00-02-18 > YMD
Time < 11:45:00 >
```

```
Date < 00-02-18 > YMD
Time < 11:45:00 >
```

```
Date < 00-02-18 > YMD
Time < 11:45:00 >
```

```
4. Mode      5. Clock
                (2/2)
```

3. End Setting

- Press [STOP] key to return to the MAIN MENU.

```
1. Measure  2. Submenu
3. Cal.      (1/1)
```

► If [STOP] key is pressed, the setting is canceled and The SUB MENU 2/2 is restored.

Chapter 4

Maintenance

After measurements are finished for the day, turn OFF the power.

Chapter 4 explains the maintenance of the system.

4-1 Outline

4-1-1 Frequency of Maintenance

4-2 Daily Maintenance

4-2-1 Cleaning the Plate Tray

4-2-2 Cleaning the Plate Transfer Part

4-3 Periodical Maintenance

4-3-1 Replacement of Thermal Printer Paper

4-3-2 Cleaning the Probe

4-3-3 Cleaning the Twin Pipette II

4-3-4 Replacement of Nozzle O-ring



4-1 Outline

4-1-1 Frequency of Maintenance

The following table shows the parts that require maintenance and the frequency of maintenance.

Perform daily or periodical maintenance according to the table.

	Cleaning part	Frequency	Page
*	Cleaning of Plate Tray	Daily	4-2-1
*	Cleaning of Plate Transfer Part	Daily	4-2-2
	Replacement of Thermal Printer Paper	When a red line appears on the both sides	4-3-1
*	Cleaning of Probe	Once every 500 measurements	4-3-2
*	Cleaning of Twin Pipette II	Once a month	4-3-3
	Replacement of Nozzle O-ring	About once a year	4-3-4



Wear protective gloves to prevent exposure to pathogenic microbes for cleaning of the parts marked with "*" on the table above.

Separate used parts for replacement and cleaning tools from general waste and discard them according to local regulations on biohazardous wastes.

4-2 Daily Maintenance

4-2-1 Cleaning the Plate Tray



Wear protective gloves to prevent exposure to pathogenic microbes.



Separate used samples, tips and protective gloves from general waste and dispose of them according to local regulations on biohazardous waste.

Discard the used plates in the plate tray.

After measurements are finished for the day (or whenever necessary), discard them.

4-2-2 Cleaning the Plate Transfer Part



Wear protective gloves to prevent exposure to pathogenic microbes.



Separate used samples, tips and protective gloves from general waste and dispose of them according to local regulations on biohazardous waste.

When the plate transfer part becomes dusty and dirty, wipe the part with soft cloth or cotton swabs.

- For cleaning the table, select [2. Table] on the Maintenance Menu of the Sub Menu. If [Please turn off.] is displayed after the plate transfer part is drawn back to the inside of the system, turn off the power of analyzer.

Wipe dirt adhered to the surrounding area of the plate setting with soft cloth or cotton swabs.



4-3 Periodical Maintenance

4-3-1 Replacement of Thermal Printer Paper

A red line on both sides of the printer paper is the sign of paper running short. The line is appeared, replace it with a new roll. One roll of paper can be used for approximately 500 measurements.

Requirements Thermal printer paper, Scissors

1. Open the Paper Cover and cut printer paper

- Make sure that the MAIN MENU is displayed.

1. Measure 2. Submenu
3. Cal. (1/1)

- Open the Paper Cover.
If the paper remains in the printer, cut it with scissors and remove the rolled paper.
- If no paper remains in the printer, remove the tube and go on to Procedure 3.

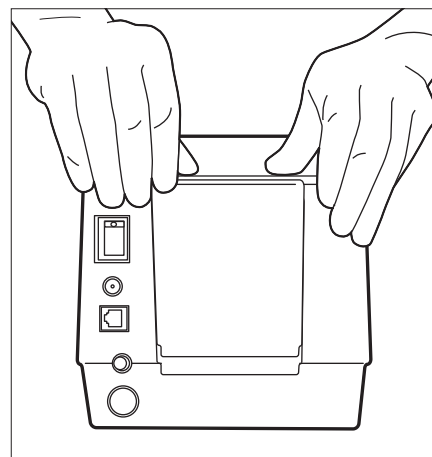

2. Remove the remained paper

- Press [FEED] key. Pick and remove the remaining paper, as it is fed out.



3. Prepare new printer paper

- Cut off a single turn of the paper of the new roll.
Cut the paper end straight to avoid a paper jam.

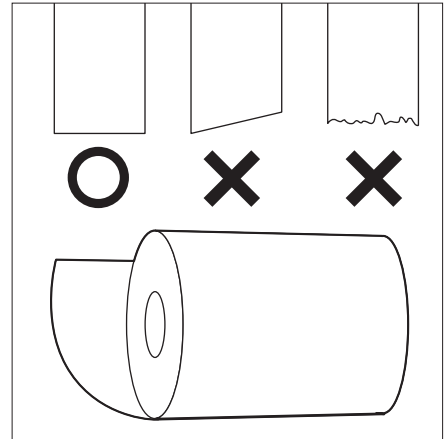

4. Set the new printer paper

- Place the new roll of paper in the paper holder, with the paper end facing up.
- Be careful of the paper cutter.
- Insert the paper end into the slot.
The paper starts to be rolled and fed automatically.
- After rolling-up of the paper is completed, press [FEED] key more than once.

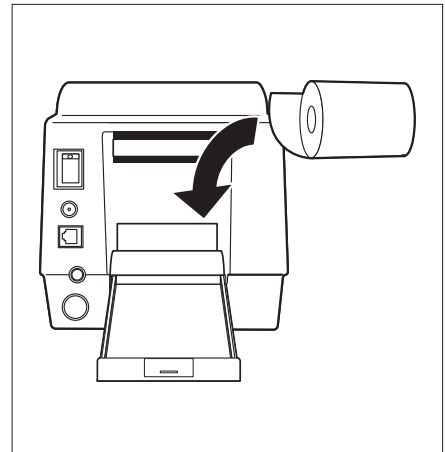

► Press [FEED] key to get the printer ready.

5. Close the paper cover

- Close the paper cover, lifting it carefully and then pushing it into the operating unit.

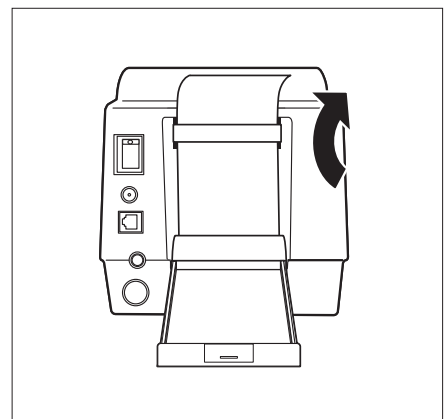

4-3-2 Cleaning the Probe

For probe cleaning, perform measurements with the check plate.
If an error occurs after the measurement, clean the probe according to the following procedure.

1. Prepare the check plate.



Correctly insert the check plate so that the arrows on the check plate face forward.

- Select [3. Check Meas] on the Maintenance Menu.
- Set the check plate and press [START] key.



- The analyzer reads the bar code of the check plate automatically.

```
Start Check MEAS
Stop(STOP)
```

- After the bar code is read, the plate moves to the optical block automatically and the check measurement starts. Then check results are printed.

```
Measuring CHK 020
Stop(STOP)
```

SE-1520 V1.00 1999-07-01 10:25 Probe test
Good

e.g.: Normal printing

SE-1520 V1.00 1999-01-17 11:34 Probe test			
Error			
	Probe1	Probe2	Probe3
Level1	o	o	o
Level2	o	x	o
Level3	x	x	x

e.g.: Abnormal printing

If an error occurs, clean the point of contact shown in the next page.

2. When errors are detected



Wear protective gloves to prevent exposure to pathogenic microbes.



Separate used samples, tips and protective gloves from general waste and dispose of them according to local regulations on biohazardous waste.

- Select [1. Probe] on the Maintenance Menu of the Sub Menu.
If [Please turn off.] is displayed, turn off the power of analyzer.
- Place the analyzer on the side after the power is off and open the maintenance cover.
- Probe pins can be found the maintenance cover is opened.
Wipe off the dirt adhered to the probe pins using cotton swabs.

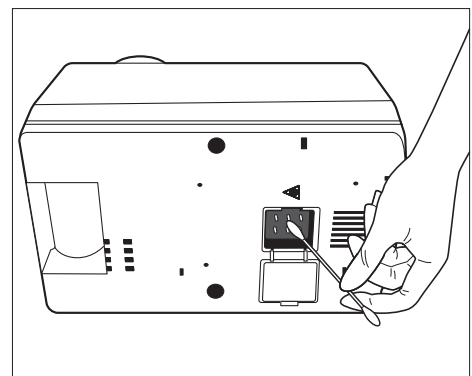

4-3-3 Cleaning the Twin Pipette II

1. Replacement of nozzle cap

- By using nozzle caps, precipitate from reference solution adheres to the inside of the nozzle caps. When a large amount of precipitate from reference solution is adhered to the inside of the nozzle cap, remove the nozzle cap and replace it with a new or clean nozzle cap. Using a nozzle cap with a large amount of precipitate from reference solution adhered contaminates reference solution and correct measurement results can not be obtained.

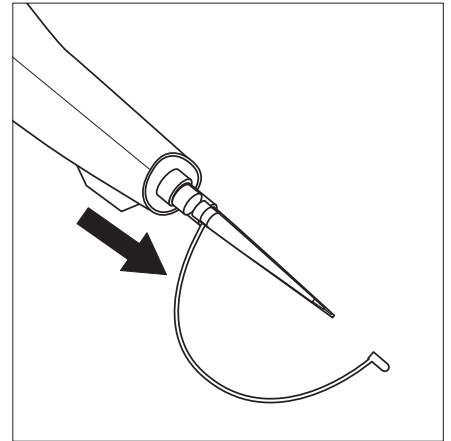

2. Cleaning the nozzle cap

- When a large amount of precipitate from reference solution is adhered to the inside of the nozzle cap, wash the inside of the nozzle cap with refined water to remove the precipitate from the reference solution. If the nozzle cap is used again, wipe it out with tissue paper, etc. and make sure that the nozzle cap is dry before using.

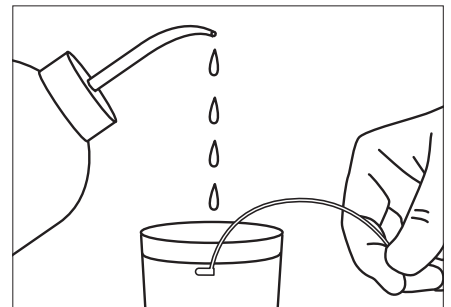

3. Replacement of nozzle pipe

- The nozzle tip can be damaged easily because the tip is thin. If the nozzle tip bends, correct pipetting becomes impossible. When the nozzle tip bends, remove the bushing and replace the bent nozzle with a spare nozzle pipe.

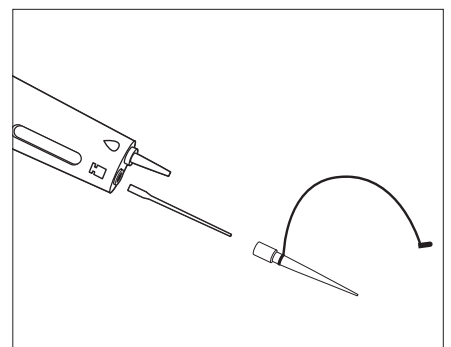

Maintenance when pipettes are not used for a long period

If a pipette is not used more than for one month, discard reference solution in the syringe, dip the nozzle tip in distilled water and clean the syringe by performing suction and drainage of water a few times. If the pipette is left untouched without cleaning after it is used, precipitate from reference solution blocks the nozzle or piston, which leads to system failure.



4-3-4 Replacement of Nozzle O-ring

The tip where the pipetting tip is attached has 2 nozzle O-ring. Worn-out nozzle O-ring leads to incorrect sealing or sampling. Replace nozzle O-ring (large and small) about once a year.

Replacement of nozzle O-ring

1. Cut and remove the attached nozzle O-ring with a needle.
Do not injure the nozzle, otherwise a correct data can not be obtained.

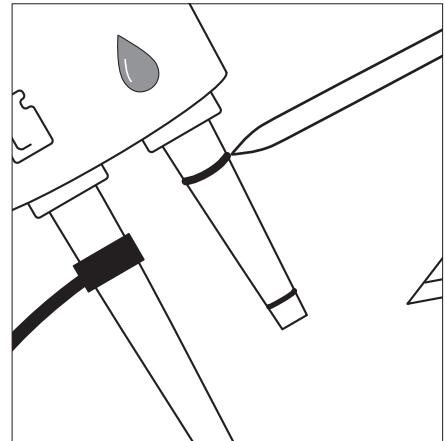

2. Remove chips before insert new nozzle O-ring for replacement.

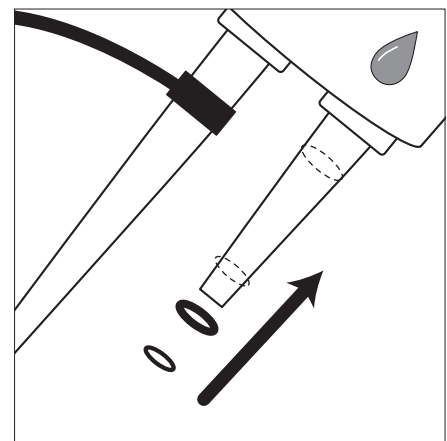

**Replace the two nozzle O-ring simultaneously.
Do NOT injure the nozzle, When cut the attached nozzle O-ring.**

MEMO

Chapter 5

Troubleshooting

5-1 Error Messages

5-2 Trouble Messages



5-1 Error Messages

If an error occurs, an alarm sounds and the error message is displayed. Press [STOP] key to stop the alarm. The error is cancelled and the Main Menu is displayed. To avoid the recurrence of errors, confirm that the Main Menu is displayed and take the proper measures described below. Confirm the condition, turn off the power and contact your distributor.



Wear protective gloves to prevent exposure to pathogenic microbes.



Separate used samples, tips and protective gloves from general waste and dispose of them according to local regulations on biohazardous waste.

Description and error messages	Problems and causes	Remedy.
<p>E01</p> <p>E01 Mispipetting OK (ENTER)</p>	<ul style="list-style-type: none"> The pipette was not removed within 8 seconds after pipetting. Operation failure. 	<ul style="list-style-type: none"> Remove the pipette within 5 seconds after pipetting.
<p>E05</p> <p>E05 Plate Miss Set. OK (ENTER)</p>	<ul style="list-style-type: none"> The plate is not set or set in the opposite direction. The barcode was not read correctly. 	<ul style="list-style-type: none"> Wipe dirt off the table. Make sure that foreign matter is not adhered to the plate. Set the plate correctly.
<p>E10</p> <p>E10 Power down OK (ENTER)</p>	<ul style="list-style-type: none"> System power was turned off during measurement. 	
<p>E15</p> <p>E15 Unknown item OK (ENTER)</p>	<ul style="list-style-type: none"> The correct plate is not set. Item information is not registered. Not read correctly. 	<ul style="list-style-type: none"> Set the correct plate. Check the setting items.
<p>E16</p> <p>E16 Remove plate OK (ENTER)</p>	<ul style="list-style-type: none"> The E-plate was not disposed. 	<ul style="list-style-type: none"> Remove the E-plate using tweezers. Check if the E-plate transfer part is clean.
<p>E20</p> <p>E20 Card misread OK (ENTER)</p>	<ul style="list-style-type: none"> Defective magnetic card. Defective magnetic card reader. 	<ul style="list-style-type: none"> Read the magnetic card again.

Description and error messages	Problems and causes	Remedy.
<h2 data-bbox="129 443 272 506">E25</h2> <div data-bbox="129 528 528 607" style="border: 1px solid black; padding: 5px;"> E25 Wrong card OK (ENTER) </div>	<ul style="list-style-type: none"> • The magnetic card is not correct. • Defective magnetic card. 	<ul style="list-style-type: none"> • Insert the correct card.
<h2 data-bbox="129 651 272 714">E26</h2> <div data-bbox="129 736 528 815" style="border: 1px solid black; padding: 5px;"> E26 Wrong stripe OK (ENTER) </div>	<ul style="list-style-type: none"> • The stripe of the magnetic card is not correct. • Defective magnetic card. 	<ul style="list-style-type: none"> • Read the correct stripe.
<h2 data-bbox="129 860 272 922">E30</h2> <div data-bbox="129 945 528 1023" style="border: 1px solid black; padding: 5px;"> E30 Wrong date/time OK (ENTER) </div>	<ul style="list-style-type: none"> • The clock is not adjusted correctly. • The batteries are dead. 	<ul style="list-style-type: none"> • Reset the date and time.
<h2 data-bbox="129 1068 272 1131">E35</h2> <div data-bbox="129 1153 528 1232" style="border: 1px solid black; padding: 5px;"> E35 BAR misread OK (ENTER) </div>	<ul style="list-style-type: none"> • The plate barcode is not read successfully. • Abnormal barcode sensor • Table is dirty. • Foreign matter is adhered to the plate. 	<ul style="list-style-type: none"> • Wipe dirt off the table. • Make sure that foreign matter is not attached to the plate. • Set the plate correctly.
<h2 data-bbox="129 1276 272 1339">E40</h2> <div data-bbox="129 1350 528 1429" style="border: 1px solid black; padding: 5px;"> E40 BCR error OK (ENTER) </div>	<ul style="list-style-type: none"> • The hand-held barcode reader is not set correctly.(e.g.baud rate) • The hand-held barcode reader is not connected correctly. • The hand-held barcode reader is broken. 	<ul style="list-style-type: none"> • Check the setting (e.g. baud rate) of the hand-held barcode reader. • Connect the hand held barcode reader correctly.
<h2 data-bbox="129 1485 272 1547">E45</h2> <div data-bbox="129 1570 528 1648" style="border: 1px solid black; padding: 5px;"> E45 Communication OK (ENTER) </div>	<ul style="list-style-type: none"> • Transmission error occurred. • Transmission time out occurred. 	<ul style="list-style-type: none"> • Set the transmission setting again. • Connect the cable again. • Set PC again.
<h2 data-bbox="129 1693 272 1756">E50</h2> <div data-bbox="129 1778 528 1856" style="border: 1px solid black; padding: 5px;"> E50 Memory: results OK (ENTER) </div>	<ul style="list-style-type: none"> • Memory storing measurement results is abnormal. • The power was turned off during writing to or deleting from memory. • Abnormal memory board 	<ul style="list-style-type: none"> • If the same trouble occurs, contact your distributor
<h2 data-bbox="129 1901 272 1964">E51</h2> <div data-bbox="129 1975 528 2054" style="border: 1px solid black; padding: 5px;"> E51 Memory: history OK(ENTER) </div>	<ul style="list-style-type: none"> • Trouble history memory abnormality. • The power was turned off during writing to or deleting from memory. • Defective memory board 	<ul style="list-style-type: none"> • If the same trouble occurs, contact your distributor

Description and error messages	Problems and causes	Remedy
W01 W01 No lot data	<ul style="list-style-type: none"> Measurement is performed without reading in any information on the magnetic card. 	<ul style="list-style-type: none"> Carry out the calibration by the magnetic card in the box of E-Plate before the measurement. If the same trouble occurs, contact your distributor.
W05 W05 TEMP error	<ul style="list-style-type: none"> Measurement is performed at the outside of the room temperature range. (10-30°C) 	<ul style="list-style-type: none"> Be sure to measure at the specified room temperature. If the same trouble occurs, contact your distributor.
W10 W10 Stability ERR * * * * * <small>※ Note</small>	<ul style="list-style-type: none"> Stability error 	<ul style="list-style-type: none"> Make sure the setting for the sample type is correct. If the same trouble occurs, contact your distributor.
W15 W15 Out of L limit * * * * * <small>※ Note</small>	<ul style="list-style-type: none"> Measurement result is lower than the lower limit of the measurement range. 	<ul style="list-style-type: none"> Make sure the setting for the sample type is correct. Make sure the Lot No. on the display is same as the one on the laminated aluminum package of the E-Plate. If the same trouble occurs, contact your distributors.
W16 W16 Out of U limit * * * * * <small>※ Note</small>	<ul style="list-style-type: none"> Measurement result is higher than the upper limit of the measurement range. 	<ul style="list-style-type: none"> Make sure the setting for the sample type is correct. Make sure the Lot No. on the display is same as the one on the laminated aluminum package of the E-Plate. If the same trouble occurs, contact your distributor.
W20 W20 Out of normal L * * * * * <small>※ Note</small>	<ul style="list-style-type: none"> Measurement result is lower than the lower limit of the normal measurement range. 	<ul style="list-style-type: none"> Make sure the setting for the sample type and its normal measurement range are correct. Make sure the Lot No. on the display is same as the one on the laminated aluminum package of the E-Plate. If the same trouble occurs, contact your distributor.
W21 W21 Out of normal U * * * * * <small>※ Note</small>	<ul style="list-style-type: none"> Measurement result is higher than the upper limit of the normal measurement range. 	<ul style="list-style-type: none"> Make sure the setting for the sample type and its normal measurement range are correct. Make sure the Lot No. on the display is same as the one on the laminated aluminum package of the E-Plate. If the same trouble occurs, contact your distributor.
W25 W25 Connection ERR	<ul style="list-style-type: none"> Connection error 	<ul style="list-style-type: none"> Make sure the sample and reference solution are drawn and pipetted properly. If the same trouble occurs, contact your distributor.

Note: "*****" indicates the name of failed measurement item.

e.g. 「**W21** Out of normal U Na 」

5-2 Trouble Messages

When trouble occurs with the analyzer, measurement stops, an alarm sounds and the trouble message will be displayed. Press [STOP] key to stop the alarm. The error is cancelled and the Main Menu is displayed. According to the System Initializing Confirmation Display, press [ENTER] key and the internal system of the analyzer is initialized. When initialization is finished, the Main Menu is displayed.

To avoid recurrence of the trouble, confirm that the Main Menu is displayed, then take the measures described below. Please confirm the condition, turn off the power and contact your distributor.

IMPORTANT

When trouble occurs during measurement, perform measurement again. It may influence the result measured before the trouble occurred. When the measured result appears to be abnormal, start the measurement again.



Wear protective gloves to prevent exposure to pathogenic microbes.



Separate used samples, tips and protective gloves from general waste and dispose of them according to local regulations on biohazardous waste.

Description and troubles	Problems and causes	Remedy
<p>T05</p> <p>T 0 5 T e m p c o n t r o l OK (ENTER)</p>	<ul style="list-style-type: none"> • The temperature adjustment circuit is broken. • Adjustment became impossible because the outside temperature is out of the specification temperature range (10 - 30°C). • Connectors of the heater or sensor are disconnected. 	<ul style="list-style-type: none"> • Check the outside air temperature. • If the same trouble occurs, contact your distributor.
<p>T10</p> <p>T 1 0 C o n t a c t t r o u b l e OK (ENTER)</p>	<ul style="list-style-type: none"> • Abnormality in the movement of the temperature adjustment block to the starting point sensor position. • Connectors of the motor or sensor are disconnected. 	<ul style="list-style-type: none"> • Turn on the power again. • Make sure that there are no obstacles. • If the same trouble occurs, contact your distributor.
<p>T15</p> <p>T 1 5 T r a n s . t r o u b l e OK (ENTER)</p>	<ul style="list-style-type: none"> • Abnormality in the movement of the plate movement frame to the starting point sensor position. • Connectors of the motor or sensor are disconnected. 	<ul style="list-style-type: none"> • Turn on the power again. • Make sure that there are no obstacles. • If the same trouble occurs, contact your distributor.

Description and troubles	Problems and causes	Remedy
<h2>T20</h2> <div style="border: 1px solid black; padding: 5px; margin-top: 10px;"> T20 PMC trouble OK (ENTER) </div>	<ul style="list-style-type: none"> ● Abnormal PMC ● Internal cables are disconnected. 	<ul style="list-style-type: none"> ● Turn on the power again. ● If the same trouble occurs, contact your distributor.
<h2>T25</h2> <div style="border: 1px solid black; padding: 5px; margin-top: 10px;"> T25 Amp trouble OK (ENTER) </div>	<ul style="list-style-type: none"> ● Abnormal analogue circuit of measurement system. ● Abnormal reference voltage. ● Abnormal off setting of measurement circuit. ● AD converter is broken. 	<ul style="list-style-type: none"> ● Turn on the power again. ● If the same trouble occurs, contact your distributor.
<h2>T35</h2> <div style="border: 1px solid black; padding: 5px; margin-top: 10px;"> T35 Barcode sensor OK (ENTER) </div>	<ul style="list-style-type: none"> ● The plate bar code cannot be judged by A/D count value. ● Abnormal barcode sensor ● The plate is dirty. 	<ul style="list-style-type: none"> ● Clean the table.
<h2>T40</h2> <div style="border: 1px solid black; padding: 5px; margin-top: 10px;"> T40 Memory: product OK (ENTER) </div>	<ul style="list-style-type: none"> ● Abnormal product information storage memory ● The power was turned off during writing to or deleting from memory. ● Defective memory board 	<ul style="list-style-type: none"> ● If the same trouble occurs, contact your distributor.
<h2>T41</h2> <div style="border: 1px solid black; padding: 5px; margin-top: 10px;"> T41 Memory: mechanism OK (ENTER) </div>	<ul style="list-style-type: none"> ● Abnormal product information mechanism memory ● The power was turned off during writing to or deleting from memory. ● Defective memory board 	<ul style="list-style-type: none"> ● If the same trouble occurs, contact your distributor.
<h2>T42</h2> <div style="border: 1px solid black; padding: 5px; margin-top: 10px;"> T42 Memory: setup OK (ENTER) </div>	<ul style="list-style-type: none"> ● Abnormal memory storing user setting values (e.g. option setting) ● The power was turned off during writing to or deleting from memory. ● Defective memory board 	<ul style="list-style-type: none"> ● If the same trouble occurs, contact your distributor. ● Set (enter) the user setting values again because the values are initialized or returned to the former setting values.
<h2>T43</h2> <div style="border: 1px solid black; padding: 5px; margin-top: 10px;"> T43 Memory: parameter OK (ENTER) </div>	<ul style="list-style-type: none"> ● Abnormal measurement information storage memory (e.g. magnetic card information) ● The power was turned off during writing to or deleting from memory. ● Defective memory board 	<ul style="list-style-type: none"> ● If the same trouble occurs, contact your distributor.

Chapter 6

Appendix

6-1 Transmission Specifications

6-1-1 External Output Format

6-1-2 Block Structure

6-1-3 Format of Measurement Results

6-2 After-sales Service



6-1 Transmission Specifications

6-1-1 External Output Format

External output format	Bit-serial output in compliance with RS-232 C
Transmission format	Start-stop system (asynchronous)
Data format	One character is composed of the following 11 bits. Start bit: 1 bit Data bit: 7 bit (ASCII code) Parity bit: 1 bit (even parity) Stop bit: 2 bit
Baud rate	9600bps
Hand shake	Control by CTS or RTS is possible. (By default setting, this control is not performed.) XON/XOFF control is not available.
Time gap	Two second waiting time is inserted between each block (from<ETX> to <STX>).
Forcible termination	Data transmission may be interrupted forcibly by key operation. It is not promptly suspended by pressing a key, but transmission continues until <ETX> is output.

6-1-2 Block Structure

The block structure has a certain rule. One block consists of start, data and end. This is illustrated as below in the following explanations.



- **Start (S)**

The start of each block is < STX >.

The start of block is described as S in the following illustration.

- **Data**

The data (text) of each block is the main body of transmission content, and is described by ASCII character arrangement. < CR >, < LF >, < RS > or < US > is sometimes involved in the data. Controlling characters other than these are not included.

- **End (E)**

The end of each block is < ETX >.

The end of block is described as E in the following illustration.

6-2 After-sales Service

■ Warranty

A warranty is included in the packaging box for this analyzer. The warranty is necessary when the analyzer needs to be repaired. After filling in the required information and confirming the described contents, keep the certificate in a safe place.

■ About repair

When the analyzer does not function well	Please contact distributor.
Repair within the guaranteed period	Repair is made under conditions of the warranty.
Repair after the warranty has expired	A repair fee is necessary.

MEMO

SUPPLIED BY

ARKRAY, Inc.

57 Nishi Aketa-cho, Higashi-kujo
Minami-ku, Kyoto 601-8045, JAPAN

MANUFACTURED BY

ARKRAY Factory, Inc.

1480 Koji, Konan-cho, Koka-shi
Shiga 520-3306, JAPAN

arkray